

Catalogue 2011

Inverters and electrical systems
for residential photovoltaic
applications



EATON

Powering Business Worldwide



All about safety for solar energy

Using free energy – safe for its consumers.

The Sun provides 15,000 times more energy than consumed worldwide – reliably and free of charge. Modern photovoltaic installations harness this energy by using solar cells on the roof, which convert the sunlight efficiently and sustainably into electric power. The generation of renewable electricity offers great potential for the future, but means a special challenge, too. The irresistible power of the sun has to be restrained and professionally protected to prevent dangerous situations. For this reason, Eaton provides a full range of high-quality components including inverters and switchgear for residential grid-connected and grid-independent photovoltaic applications.

Eaton's solutions

Actively shape the future with safe photovoltaic systems and Eaton.

Photovoltaic power plants convert sunlight directly into electrical energy. For this purpose, photovoltaic modules are used. A differentiation is made between grid-independent systems and systems coupled to the power grid. Photovoltaic systems that are coupled to the power grid feed the generated power directly into the electrical grid. There is no need for sophisticated intermediate storage. A system of this type consists of photovoltaic modules, one or more inverters and switchgear for operation, maintenance and protection in case of a fault, for example, DC string protection, DC surge protection, DC switch-disconnector, residual current device (RCD), AC surge protection and xComfort system (optional). To reach the necessary DC input voltage for the inverter, PV-modules are connected in series (as a string).

To increase the power of the system, two or more strings are connected in parallel. All electrical systems need to be isolated, protected and switched to be made safe. Switchgear also need protection in the form of enclosures. Eaton provides a comprehensive range of components for all of these applications from one source.

Disconnecting, switching and protecting.

Inverters convert the DC current obtained from photovoltaic modules to AC current. The frequency and voltage characteristics are adapted to those of the public power grid to make solar energy useable. Reliable protection and main switches ensure a safe operation. Eaton offers the right solutions here: Safety grid disconnection devices, inverters from 1500 up to 4000 W for indoor solutions, as well as 4000 W & 4600 W for outdoor application.

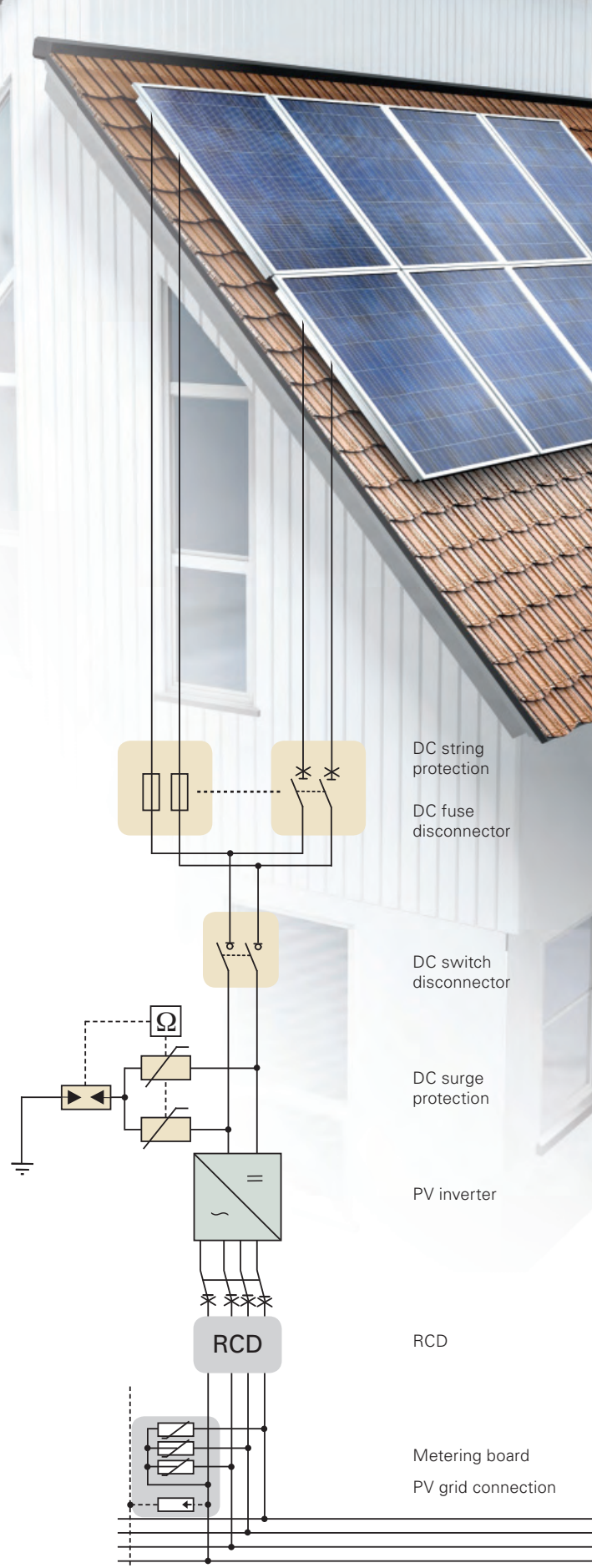

The energy of the sun, converted by Eaton

PV inverter

Grid-connected inverter range from 1500 W up to 4600 W

Eaton offers a complete range of monophasic inverters from 1500 W up to 4600 W, to serve the individual requirements of each PV-system. This range is suitable for mono- and polycrystalline PV-arrays up to 40m². The maintenance-free inverters are highly reliable and easy to install. The embedded LCD display makes them easy to operate and service. A compact, sleek and modern design makes the Eaton inverters unique. Compared to similar products of the same size, the Eaton inverter's power capacity is higher. The Maximum Power Point Tracking function yields optimum conversion efficiency. What's more, a no-fan design combined with natural convection cooling assures a particularly silent operation and keeps the device clean.



Further features are:

Standard RS-232

Embedded ENS that complies with VDE 0126-1-1/DK5940

Indoor use

The IP43 – ISG series is suitable for indoor use. Exposure to rain, moisture, water or direct sunlight is not recommended (direct sunlight will increase internal temperatures, thus reducing efficiency).

Outdoor use

The IP65 – ISG series is suitable for indoor and outdoor use. Exposure to direct sunlight is also not recommended (direct sunlight increases internal temperatures, thus reducing efficiency).

Specifications

All inverters are designed for ambient temperatures within the specified range (-20 to +55 °C). For optimum operation, an ambient temperature within the range of 0 to +40 °C is recommended. The AC grid voltage has to be between 190 and 256 V and 50 Hz (Italy 260 VAC).



**The energy of the sun –
the quality of Eaton.**

The total power of a photovoltaic system does not only depend on the area of installed PV-modules but also on the adjustment and slope of the modules. Also components such as the inverter greatly affect the efficiency. By using Eaton's inverters, maximum power is ensured.

Safe disconnection and protection of PV arrays



DC disconnection

DC switch disconnectors

The IEC 60364-7-712 standard requires the use of a switch-disconnector between the photovoltaic array and the inverter. Eaton provides enclosed and open switch-disconnectors for voltages up to 1000 V DC. They can be used to establish separate switching points as required by the standard VDI 6012, allowing for a defective inverter, for example, to be safely disconnected. All switch-disconnectors switch on two poles and are suitable for unearthed systems. All switches are certified by the TÜV.



Compact disconnectors for inverters

Eaton offers both enclosed and open switch-disconnectors. P-SOL open switch-disconnectors are intended for

customized enclosures or inverters. They are installed on 35 mm top-hat rails; their terminals facilitate the connection of all conventional conductor types.

Perfectly enclosed for outdoor installation

SOL switch-disconnectors in enclosures are ready to install. Connection variants for 2 and 3, or 4 strings, as well as for the most commonly available connector type, MC4 or metric cable glands, ensure problemfree integration in different system concepts.

The enclosure is rated to the IP65 degree of protection and thus facilitates outdoor installation. Locking capabilities offer protection during service. A pressure equalization element prevents collection of condensation and thus any malfunctions due to flashovers.

Hazard-free fire-fighting

PV fireman's switch

A house is on fire. A fire-fighting appliance approaches. The fire fighters climb out, see a solar installation – and can do very little.

The fire services can frequently do little else than rescue persons and animals and prevent neighbouring buildings from catching fire. The reason being that PV installations generate voltages up to 1000 V, which are still generated even after the power inverter is switched off. The Eaton fireman's switch SOL30-SAFETY provides the solution, which disconnects the cable from the solar panels to the power inverters facilitating fire fighting without an electrical hazard.



Small investment, large protection

VDE 0100-712 stipulates a DC circuit-breaker, but not the location where it is installed: Frequently, the circuit-breaker is integrated into the inverter, so that the line between the power inverter and house connection is protected, but

the modules and DC lines are still subjected to DC voltages of up to 1000 V and up to ~8A per string. Our fireman's switch SOL30-SAFETY disconnects the cables between the solar modules and the power inverter with manageable effort at a reasonable cost.

Ingeniously simple and simply ingenious

The fireman's switch is simply installed in the immediate vicinity of the PV module in the DC current line between the panel and power inverter. The PV modules are automatically switched off by

the undervoltage release in the fireman's switch, should the fire crew get the electrical utility company to de-energize the location of the fire or decide to locally actuate the PV-OFF switch. The SOL30-SAFETY – full control instead of controlled burn out.

DC string protection

String protection makes sense if the PV system has 3 or more strings and can be made with a DC fuse disconnecter or a DC string circuit breaker. In addition to fuses, protection of photovoltaic strings is provided by string circuit-breakers. String protection devices protect photovoltaic modules from fault currents. They prevent reverse currents from intact modules to modules with a short circuit. The advantage of string circuit breakers, in comparison to fuses, is that they are immediately ready for use after a trip, when the cause of the trip has been remedied. Eaton offers both fuse-switch disconnectors as well as string circuit-breakers. String protective devices are not enclosed and are intended for installation in customized array junction boxes. When necessary, they can be combined with other components such as side-by-side terminals or surge protective devices. The trip currents for the string circuit breaker can be set over a wide range.



Fuse disconnecter with integrated short-circuit protection

The fuse disconnecter FCFD-C10DI-SOL for cylindrical fuse-links ASFLC10-SOL of size 10 x 38 protects photovoltaic modules against short-circuit currents.

A version with a "fuse blown" indication for visualization of a blown fuse link is also available. At the same time, measurements can be made on the connected modules at the disconnection point. For service reasons, test probes are easily reachable.

String circuit-breaker

String circuit breakers PKZ-SOL are the fuseless alternative for the protection of photovoltaic modules against short circuits. They have a variable trip range that can be

optimally adjusted to the actual short-circuit current of a string. A thermal release triggers at 1.05 ... 1.3 times rated current and the magnetic release at 6 times rated current.

DC surge protection

Surge protective devices (SPD) for PV applications

SPPT2PA is especially designed for photovoltaic applications and protects the system against transient overvoltages caused by indirect lightning strikes. Versions for earthed and unearthed systems are available. Thanks to spark gap technology, galvanic separation in unearthed systems is ensured! The units can be provided prewired in an enclosure, thus ready for plug & play!



Safety and comfort for the building

AC switchgear for buildings

Miniature circuit-breakers (MCBs) and residual current devices (RCDs)

Eaton switchgear offers your customers maximum protection. The products of the Xpole series combine all of the function, mounting and safety benefits. They can be quickly and easily installed. Intelligent construction design solutions, which eliminate any mounting errors, guarantee high levels of safety during installation. The devices guarantee the end users not only protection for personnel (residual current device) but also protection of the electrical system (miniature circuit breaker). The product range is rounded off by a comprehensive range of intelligent switchgear such as remote switches, reset devices, etc.



Digital residual current circuit-breakers (RCCB)

Digital technology makes it possible to achieve a new level in tripping accuracy, which helps to avoid unwanted tripping. This occurs, for example, as a result of permanent discharge currents on electrical devices or temporary disturbances during a thunderstorm. Eaton is the first company offering the digital residual current device, which significantly reduces nuisance tripping by permanently monitoring the system status to guarantee maximum systems availability. Three LEDs following the "traffic light" principle, offer the benefit of indicating when the warning level of 30 % leakage current is reached. In this way, corrective measures can be implemented in the system, before the situation becomes more acute. This offers the end user a considerable degree of safety and comfort.

Residual current breakers with overcurrent (RCBO)

The RCBO combines the advantages of a miniature circuit-breaker and a residual current device in one unit. It saves space and offers complete protection. Benefits are fire protection, protection of persons (type 30 mA) as well as fl exible and generous space for wiring.

Additional features:

- Contact position indicator red/green
- A- and G/A-types are available
- Can be sealed with leads in the ON or OFF position
- Twin-purpose terminal (lift/open mouthed) above and below

Surge-current protected designs prevent unwanted shutdown, selective types facilitate discriminative shutdown of the defective system section.

Miniature circuit-breakers (MCB)

Whether it's plug-in terminals or screw connections, Eaton has the right circuit breakers for domestic as well as for industrial applications.

A comprehensive range of accessories such as auxiliary switches, shunt releases, reset devices and clever busbar solutions facilitate a host of applications and automation solutions.

Distribution boards

From service distribution boards to meter cabinets, energy distribution and data network cabinets, Eaton offers a fully comprehensive product range of boards. Thus, all of your infrastructure needs can be covered for residual, commercial and industrial energy distribution applications.



Surge protective devices

Threats to electrical systems due to lightning and overvoltages are made safe by Eaton's surge protective devices. The comprehensive product range offers protection up to the user. Easily fitted auxiliary switches facilitate monitoring of the functionality of the surge protective device.

You can find further information regarding Eaton switchgear for disconnecting, protecting and switching of photovoltaic systems for commercial and industrial applications at www.eaton.com/moellerproducts.

Wireless monitoring of the PV system & energy management for the building

Wireless visualization of the generated energy

Energy sensor up to 16 A and Energy-Manager

Comprehensive information from the xComfort Energy Sensor and Energy Manager: The Room Manager with integrated Energy-Manager Software enables the user to monitor the power generation of their photovoltaic system. By connecting the Eaton energy sensor to the inverter, the current feed to the grid can be read out. The data is transmitted wirelessly to the Room Manager with energy management function, where the user can easily and conveniently read parameters like U (voltage), I (current), P (power) and kWh (energy) on the display to get information about the output/input.

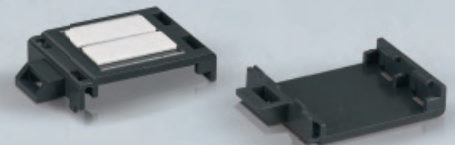

Comfort, safety and energy management – wireless house automation from Eaton.

Automation tasks such as illumination management, shading control, monitoring and warning, as well as energy-efficient control concepts for heating, ventilation and air-conditioning are easy with Eaton products, and simple to implement.

Energy management benefits

- Consumption monitoring
- Cost control
- Carbon footprint reduction

As specified by EU regulations, the actual energy consumption has to be clearly presented to the end consumer. The Eaton Energy Manager makes this possible: visualizing and controlling the energy consumption of specific electrical or gas appliances in the entire household, e.g. the washing machine, refrigerator, hot water heater, etc.

By entering the price per measured unit into the system, the cost of a full bath or a washing cycle can be calculated very quickly. The history from the last 24 hours up to the last 12 months can be read out from the archive and displayed as a value or a trend. It is also possible to be immediately alerted when a user-defined limit has been exceeded. Eaton's energy management software is a useful tool for private users to identify potential savings and to reduce their energy costs!

The safety of Eaton

Safe disconnection:

In case of fire or flooding, the current grid will be shut down by the regional electricity supplier or the fire brigade. Eaton provides you with extra safety: Remote controlled switch disconnectors ensure the disconnection of the voltage producing modules from the grid.

Safe maintenance:

Whether the photovoltaic system has to be maintained or the panels cleaned up – Eaton's DC switch disconnectors disconnect the panels from the system and help to avoid dangers while working on the roof.

Safe protection:

Even if a lightning arrester protects your home from lightning strikes, the induced overvoltages can damage the photovoltaic system. To avoid such damage, Eaton offers a solution: the DC surge protection.

Safe interaction:

The photovoltaic system converts solar energy into electricity. Efficiency and safety are provided by Eaton. We offer a full product range of efficient and protective components, which work together, from one source.





Content



Inverter

Selection Information
Technical Data

Page 14
Page 26



DC Disconnectors

Selection Information
Technical Data

Page 15
Page 28



DC String Protection

Selection Information
Technical Data

Page 17
Page 31



Surge Protection

Selection Information
Technical Data

Page 20
Page 35



Energy Management

Selection Information
Technical Data

Page 23
Page 41



PV inverter grid connected ISG

- Transformerless design
- Equipped with MC3 plugs
- High efficiency
- Fanless
- LCD display
- GFCI integrated (RCMU)
- Works with monitoring software
- ENS meets VDE 0126-1-1

sg00210



sg00210



AC output	MC3	Type designation	Article No.	Units per package
-----------	-----	------------------	-------------	-------------------

Indoor series IP43

1500 W	1 pair	ISG1I-1500/1	134753	1 / 14
2000 W	1 pair	ISG1I-2000/1	134754	1 / 14
2800 W	1 pair	ISG1I-2800/1	134755	1 / 12
3300 W	2 pairs	ISG1I-3300/1	135522	1 / 12
4000 W	2 pairs	ISG1I-4000/1	134756	1 / 12

Outdoor series IP65

4000 W	3 pairs	ISG1O-4000/1	134757	1 / 12
4600 W	3 pairs	ISG3O-4600/1	134758	1 / 6

Explanations:

MPP **M**aximum **P**ower **P**oint.

ENS Two independent main monitoring units with allocated all-pole switching devices.

GFCI **G**round **F**ault **C**urrent **I**nterrupter.

RCMU **R**esidual **C**urrent **M**onitoring **U**nit.

MC3 **M**ulti **C**ontact **3**

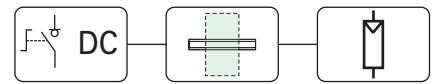

DC switch-disconnector

DC switch-disconnector P-SOL 2-poles

- Rated operational voltage 1000 VDC
- Utilization category DC-21A

wa_sg05409, wa_sg04709



Rated op. current Ie	Type designation	Article No.	Units per package
20A	P-SOL20	120934	1
30A	P-SOL30	120935	1
63A	P-SOL60	120936	1

Connection diagrams:

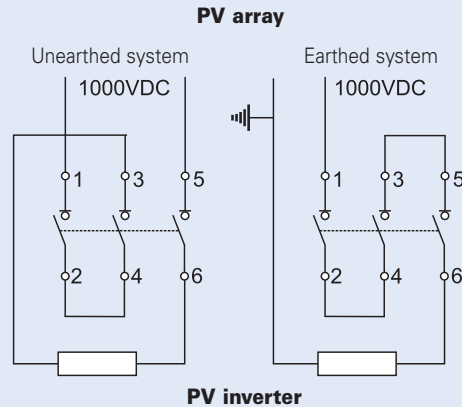

DC switch-disconnector

DC switch-disconnector SOL 2-poles as pre-wired unit with protection class II, degree of protection IP65

- Rated operational voltage 1000 VDC
- Utilization category DC-21A
- Rated operational current Ie of 20 or 30 A
- Several versions – plugs MC4 or cable glands available
- Versions for 2, 3, and 4 strings (INPUT) available

wa_sg00110



Ie	INPUT	OUTPUT	Type designation	Article No.	Units per package
MC4 version					
20A	2xMC4	1xMC4	SOL20/2MC4	120915	1
20A	4xMC4	1xMC4	SOL20/4MC4	120916	1
30A	2xMC4	1xMC4	SOL30/2MC4	120922	1
30A	4xMC4	1xMC4	SOL30/4MC4	120923	1

Version with metric cable glands

20A	2xM12	1xM16	SOL20/2MV	120919	1
30A	2xM12	1xM16	SOL30/2MV	120926	1

SOL20/2MC4
SOL30/2MC4
SOL20/2MV
SOL30/2MV

SOL20/4MC4
SOL30/4MC4

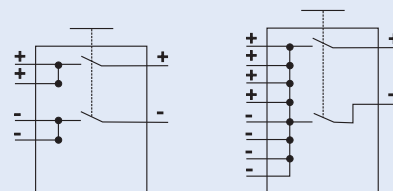

Photovoltaic - PV Off Switch, PV fireman's switch

PV Off Switch

- Degree of protection IP 65
- Tamper-proof to ISO 13850/EN 418
- Reset by pulling or turning
- Red enclosure upper section



Description	Type designation	Article No.	Units per package
Complete with guard ring, 1 NO, 1 NC	M22-SOL-PVT45PMPI11Q	150644	1
Complete with guard ring 2 NC	M22-SOL-PVT45PMPI02Q	150645	1
Surface mount enclosure, black/red cover	M22-SOL-IR1Q	150646	1
Guard ring, red, laser etched with SOLAR	M22-SOL-XGPVQ	150647	1
Guard ring, red 1	M22-XGPVQ	150648	1
Pushbutton laser etched with SOLAR	M22-SOL-PVT45P-MPIQ	150673	1
Complete 1 NO, 1 NC, can be sealed	M22-SOL-PVLPL11-230Q	152627	1

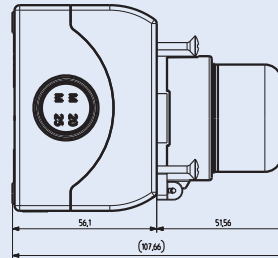
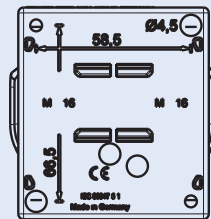
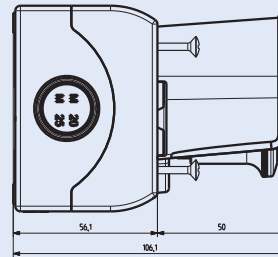
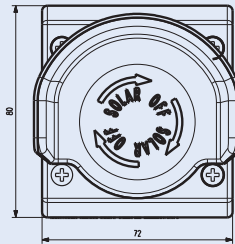

PV fireman's switch SOL30-SAFETY

DC switch-disconnector

- Rated operational voltage 1000V
- Utilization category DC-21A
- Rated operational current Ie 30A
- Remote release by undervoltage release 230V, 50Hz
- Feedback of the switching status by auxiliary contacts 1NO and 1NC
- Several versions - plugs MC3, MC4 or metric glands available

SOL30-SAFETY_HPL



Ie	INPUT	OUTPUT	Type designation	Article No.	Units per package
30A	2xMC3	1xMC3	SOL30-SAFETY/2MC3-U(230V50HZ)	144121	1
30A	2xMC4	1xMC4	SOL30-SAFETY/2MC4-U(230V50HZ)	144122	1
30A	2xM12	1M16	SOL30-SAFETY/2MV-U(230V50HZ)	144123	1

Connection diagrams:

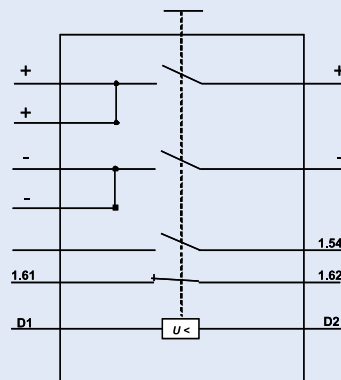

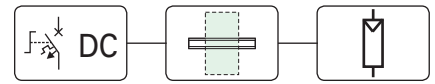

DC string circuit-breaker

DC string circuit-breaker PKZ-SOL 2-poles

- Rated operational voltage 900 VDC
- Rated current In 4, 6, 12, 20 and 30 A
- For permissible string short-circuit currents I_{sc} of 1.6 up to 22 A

wa_sg05409, wa_sg04709



le	I _{sc}	Type designation	Article No.	Units per package
4A	1.6-3A	PKZ-SOL4	144069	1
7A	2.6-5A	PKZ-SOL7	144120	1
12A	5-9A	PKZ-SOL12	120937	1
20A	9-15A	PKZ-SOL20	120938	1
30A	15-22A	PKZ-SOL30	120939	1

Connection diagrams:

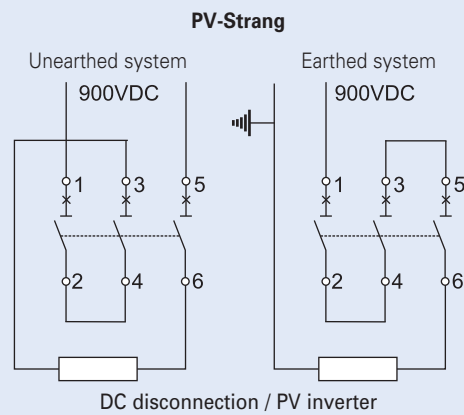

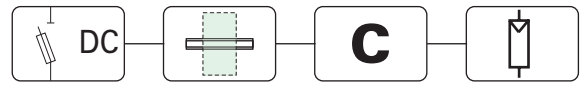

Fuse-disconnector (empty) FCFDC10DI...-SOL

- String protection of PV generator
- The visual tripping indicator indicates the tripped fuse-link
50-400 V flashing
400-1000 V permanent light
- Rated operational voltage 1000 VDC
- For cylindrical fuse-links photovoltaic application
- Lead-sealable

wa_sg00210



Number of poles / Size	Type designation	Article No.	Units per package
------------------------	------------------	-------------	-------------------

Size 10x38 FCFDC10DI, rated operational current 25 A DC

without visual tripping indicator

1	10x38	FCFDC10DI-1-SOL	137256	12 / 108
2	10x38	FCFDC10DI-2-SOL	137257	6 / 54

with visual tripping indicator

1	10x38	FCFDC10DI-1L-SOL	137258	12 / 108
2	10x38	FCFDC10DI-2L-SOL	137259	6 / 54

Photovoltaic application

Earthed system

FCFDC10DI-1-SOL

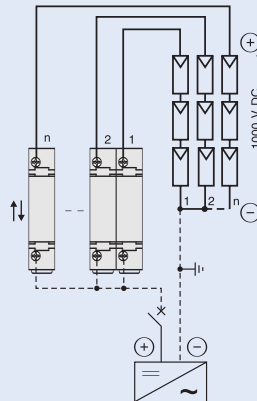

FCFDC10DI-1L-SOL

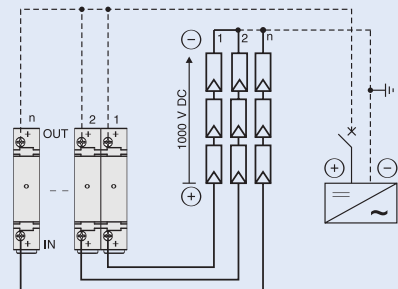

Unearthed system

FCFDC10DI-1-SOL

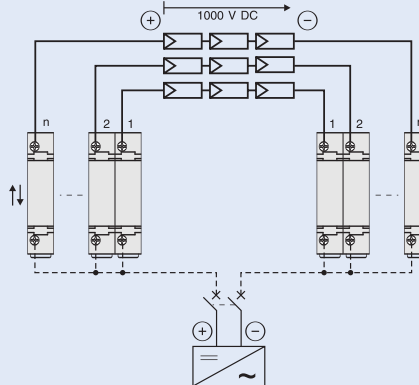

FCFDC10DI-2L-SOL

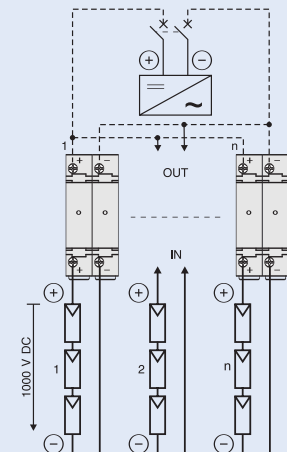

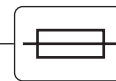
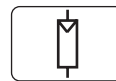

SG11008



Size / Rated current / Rated voltage	Type designation	Article No.	Units per package
Fuse-Links ASFLC10-..A-gPV-SOL Photovoltaic application			
10x38 2 A 1000 V DC	ASFLC10-2A-gPV-SOL	137279	10 / 500
10x38 4 A 1000 V DC	ASFLC10-4A-gPV-SOL	137280	10 / 500
10x38 6 A 1000 V DC	ASFLC10-6A-gPV-SOL	137281	10 / 500
10x38 8 A 1000 V DC	ASFLC10-8A-gPV-SOL	137282	10 / 500
10x38 10 A 1000 V DC	ASFLC10-10A-gPV-SOL	137283	10 / 500
10x38 12 A 1000 V DC	ASFLC10-12A-gPV-SOL	137284	10 / 500
10x38 16 A 1000 V DC	ASFLC10-16A-gPV-SOL	137285	10 / 500
10x38 20 A 1000 V DC	ASFLC10-20A-gPV-SOL	137286	10 / 500
10x38 25 A 900 V DC	ASFLC10-25A-gPV-SOL	137287	10 / 500

PV-fuse-link selection:

- ① Maximum DC operating voltage of the fuse-link must be:
 $1.2 \times V_{oc}$ of string
- ② Rated current I_n of the fuse-link must be higher than or equal to:
 $1.5 \times I_{sc}$

I_{sc} . . . short circuit current of PV module

V_{oc} . . . open circuit voltage of string

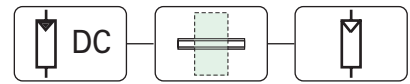

SPD-type T2 (Class C)

Max. Cont. Op. Volt. U_c Type designation Article No. Units per package

Plug-in surge arrester SPPT2PA for photovoltaic application

For earthed systems

600 V DC	SPPT2PA-600-2PE	132663	1 / 60
1000 V DC	SPPT2PA-1000-2PE	132664	1 / 60

with auxiliary switch
1000 V DC

SPPT2PA-1000-2PE-AX	132666	1 / 60
---------------------	--------	--------

For unearthed systems

600 V DC	SPPT2PA-600-2+1PE	132661	1 / 40
1000 V DC	SPPT2PA-1000-2+1PE	132662	1 / 40

with auxiliary switch
1000 V DC

SPPT2PA-1000-2+1PE-AX	132665	1 / 40
-----------------------	--------	--------

Inserts for replacement

600 V DC	①	SPPT2PA-600	132667	1
1000 V DC	①	SPPT2PA-1000	132668	1
1100 V DC	②	SPPT2PA-1100	132669	1

$V_{oc} \leq U_c$: Open circuit voltage of the PV generator shall be equal to or less than maximum continuous operating voltage of the Surge Protective Device (SPD) to protect it from damage.

V_{oc} Open circuit voltage of PV generator.

U_c Maximum continuous operating voltage of SPD.

⚠ Attention: Ensure system is de-energized before installation. Measure to ensure zero potential.

Earthed system

SPPT2PA-600-2PE
SPPT2PA-1000-2PE(-AX)

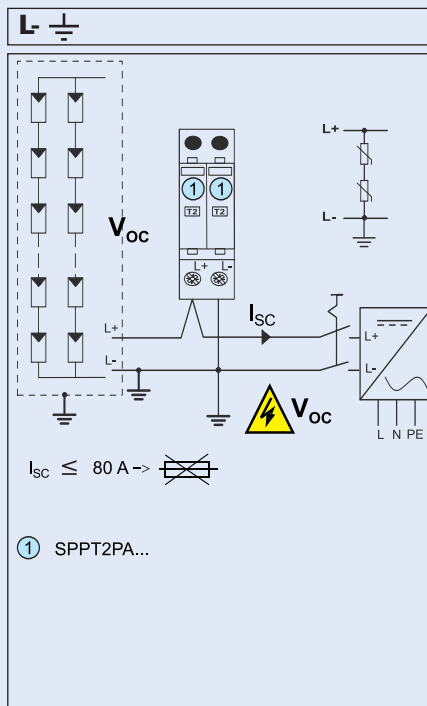

Unearthed system

SPPT2PA-600-2+1PE
SPPT2PA-1000-2+1PE(-AX)

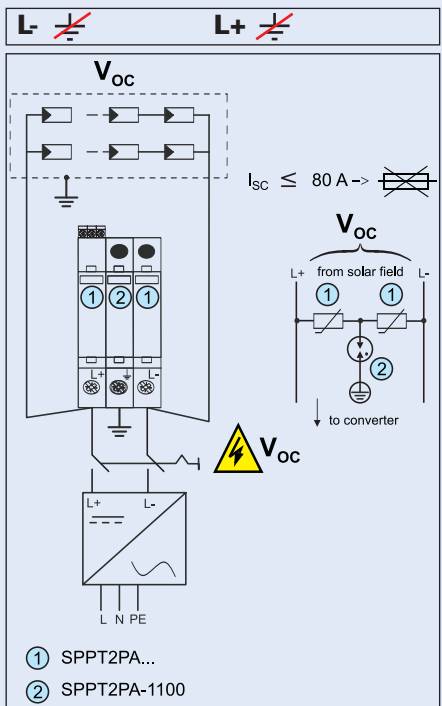

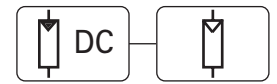

SPD-type T2 (Class C)

PV surge protective device SOL-SP as a pre-wired unit with protection class II, degree of protection IP65

- For unearthed photovoltaic systems up to 600 VDC and 1000 VDC
- Rated operational current $I_n=30$ ADC for versions MC3, MC4
- Rated operational current $I_n=32$ ADC for version with metric cable glands
- PE conductor has to be connected direct to the surge protection device PE terminal – metric cable gland M16 in the enclosure for PE conductor

wa_sg06509



V_{oc}	INPUT	OUTPUT	Type designation	Article No.	Units per package
MC3 version					
600VDC	2xMC3	1xMC3	SOL-SP600U/2MC3	144124	1
1000VDC	2xMC3	1xMC3	SOL-SP1000U/2MC3	144127	1
MC4 version					
600VDC	2xMC4	1xMC4	SOL-SP600U/2MC4	144125	1
1000VDC	2xMC4	1xMC4	SOL-SP1000U/2MC4	144128	1
Version with metric cable glands					
600VDC	2xM16	1xM16	SOL-SP600U/2MV	144126	1
1000VDC	2xM16	1xM16	SOL-SP1000U/2MV	144129	1

$V_{oc} \leq U_c$: Open circuit voltage of the PV generator shall be equal to or less than maximum continuous operating voltage of the Surge Protective Device (SPD) to protect it from damage.

V_{oc} Open circuit voltage of PV generator.

U_c Maximum continuous operating voltage of SPD.

⚠ Attention: Even when switched off, the DC disconnector is under high voltage! Ensure system is de-energized before installation. Measure to ensure zero potential.

Connection example:

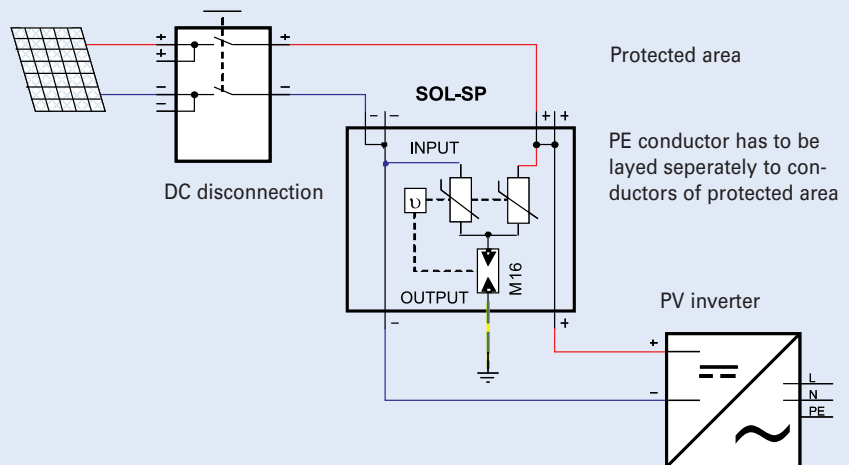

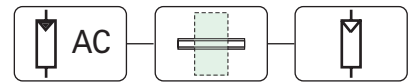

SPD-type T2 (Class C)

sg13309



Max. Cont. Op. Volt. U_C	I_n (8/20) μ s	Type designation	Article No.	Units per package
----------------------------	----------------------	------------------	-------------	-------------------

Plug-in surge arrester SPMT2PA, 1- to 4-pole

1-pole	280VAC	1x20kA	SPMT2PA-280/1	131755	12 / 120
2-pole	280VAC	2x20kA	SPMT2PA-280/2	131756	1 / 60
3-pole	280VAC	3x20kA	SPMT2PA-280/3	131757	1 / 40
4-pole	280VAC	4x20kA	SPMT2PA-280/4	131758	1 / 30
1-pole	335VAC	1x20kA	SPMT2PA-335/1	131759	12 / 120
2-pole	335VAC	2x20kA	SPMT2PA-335/2	131760	1 / 60
3-pole	335VAC	3x20kA	SPMT2PA-335/3	131761	1 / 40
4-pole	335VAC	4x20kA	SPMT2PA-335/4	131762	1 / 30
1+1p	-	-	SPMT2PA-1+NPE	131773	1 / 60
3+1p	-	-	SPMT2PA-3+NPE	131774	1 / 30

SG13109



Inserts SPMT2PA for replacement

Insert 1-pole

Insert 280VAC	20kA	SPMT2PA-280	131778	4 / 120
Insert 335VAC	20kA	SPMT2PA-335	131779	4 / 120
Insert N-PE 260VAC	30kA	SPMT2PA-NPE	131783	4 / 120

SG12809



Description	Type designation	Article No.	Units per package
-------------	------------------	-------------	-------------------

Auxiliary switch

for SPMT2PA	ASAUXSC-SPM	131785	4 / 120
-------------	-------------	--------	---------

SG12909



Lead-through terminal for SPMT2PA

ASLTT-63	131784	12 / 120
----------	--------	----------

Photovoltaic- RF System - Flush-mounted devices

r105410



Design	Type designation	Article No.	Units per package
--------	------------------	-------------	-------------------

Energy sensor

- The "energy sensor" is used to record the solar energy converted in the PV inverter and to forward this information to the Room-Manager equipped with "Energy management function". This type of device is used for capacities of 3-3680 W. It is used to determine current (A), voltage (V), power (kW) and energy (kWh). The "energy sensor" is preferably connected at the feeding point in the electrical system. The device is mounted in the switch box, the junction box or the installation box.
- Warning: The device is not calibrated and is thus not suitable for billing purposes!

0,42VA/230VAC, Measuring range 3-3680 W (max. 16A)	CEMU-01/04	136477	1
--	------------	--------	---

r105410



Design	Type designation	Article No.	Units per package
--------	------------------	-------------	-------------------

Energy sensor with external sensor

- The "energy sensor with external sensor" is used to record the solar energy converted in the PV inverter and to forward this information to the Room-Manager equipped with "Energy management function". This type of device is used for larger capacities of 15 W - 23 kW. It is used to determine current (A), voltage (V), power (kW) and energy (kWh). The energy sensor's external sensor is connected through the supply line, preferably at the feeding point in the electrical system. The device is mounted in the switch box, the junction box or the installation box.
- Warning: The device is not calibrated and is thus not suitable for billing purposes!

0.42 VA/230 VAC, Measuring range ext. sensor 15 W - 23 kW (max. 100 A)	CEMU-01/03	136476	1
--	------------	--------	---

Photovoltaic- RF System - Surface mounted devices

rf09410



Design	Type designation	Article No.	Units per package
<p>Room-Manager: white, 1 VA, 230 AC, without Bluetooth</p> <ul style="list-style-type: none"> The "Room-Manager" is a central display and operating device. In connection with the energy sensors (with or without external sensors), the solar energy emitted by the PV inverter is displayed. In addition, the device offers thoroughly tested applications such as heating and cooling for individual rooms, ventilation, time functions, shading, safety, etc., to achieve a modern electrical installation. The "Room-Manager" communicates with all devices that are part of the Eaton RF system. The most modern touch-button sensor technology makes it possible for the user to easily operate the system on site, and to program all parameters (e.g. time settings, temperature, etc.). The back-lit graphic display guarantees a simple and concise display of the most important information for the end client. The device is to be surface-mounted on a wall. Alternatively, the device can be affixed to a 55 mm or 68 mm switch box, junction box or installation box. The integrated IR interface is used for system updates or to expand functions. The device feed is carried out through the power supply line. Note: In order to obtain the exact measurement and display of the temperature, use the reference measuring device to determine the difference and then adjust the "Offset" in the MRF system. <p>Room-Manager: Energy management</p> <p>4 counter inputs (impulse counters or energy sensor), e.g. solar energy, electrical energy, water, gas, etc.</p> <p>Per input: Unit of measurement, count constant, base value, costs, CO₂ emissions</p> <p>Per input: Graphic display of progression during diverse time periods (1 day, 7 days, 30 days, 12 months)</p> <p>The display is adjustable</p> <p>Each input allows 1 threshold value followed by an "action in case this value is exceeded"; the limit value can be adjusted</p> <p>Overview display of up to 3 different counter inputs</p> <p>Room-Manager: Comfort management</p> <p>2 local buttons, freely assignable</p> <p>3 rooms for 1-level heating/cooling, adjustable time-temperature program, target/actual temperature display, operating modes can be selected, integration of 3 window contacts per room</p> <p>1 1-level ventilation, adjustable time program, operating modes can be selected, manual control</p> <p>1 time and date display, automatic switch for daylight saving times in summer/winter</p> <p>10 inputs, displays for temperature, humidity, light intensity, etc.</p> <p>10 outputs, display and operation of electrical consumers</p> <p>1 outdoor temperature, max./min/trend display, re-setting of the trend display</p> <p>3 timers, adjustable time program, operating modes can be selected, manual control</p> <p>3 shading units with time program and manual control, time program is adjustable</p> <p>1 holiday function, time and date are adjustable</p> <p>1 presence simulator, settings adjustable for a max. of 10 consumers, time and activation function</p> <p>3 logic operations with 2 inputs each, AND/OR connection</p> <p>2 scenes with 6 functions each, function is adjustable</p> <p>1 request for total heating</p> <p>1 request for total cooling</p> <p>Battery status display and advance warning for all battery-operated devices that are assigned to the Room-Manager</p> <p>Software update conducted via IRDA</p> <p>Adjustable password protection</p> <p>Multi-language menu (depending upon article number)</p> <p>General settings</p> <p>Room-Manager: Safety management (additional function)</p> <p>This fee-based function can be activated at www.moeller.at</p> <p>2 separate areas can be monitored (e.g. indoors, outdoors, upper floor, etc.)</p> <p>2 areas can be activated/deactivated individually or together</p> <p>3 inputs to activate/deactivate, alternatively 4-digit codes can be used</p> <p>10 additional inputs for safety (motion detectors, window contacts, sensors, etc.)</p> <p>2 outputs for "Safety" alert purposes (sirens, flashing lights)</p> <p>5 additional inputs for smoke detectors, regardless of whether Safety function is activated/deactivated</p> <p>1 output for "Smoke detector" alert (sirens, flashing lights)</p> <p>Adjustable time delay for activation/deactivation upon entering/leaving a room</p> <p>Attention: This is a warning function, not a smoke/fire alarm or other alarm system!!!</p>			
GB,NO,SE,FI	CRMA-00/03	118783	1
GB,NL,FR,DE,IT	CRMA-00/04	118784	1
GB,RO,HU,PL,TR	CRMA-00/05	118785	1
GB,DE,CZ,GR	CRMA-00/06	118786	1

Photovoltaic- Energy Management

RF01506



Design	Type designation	Article No.	Units per package
--------	------------------	-------------	-------------------

USB-RS232 adapter cable

- The "USB-RS232 adapter cable" is used to connect the PV inverter (with RS232 interface) to the laptop/notebook/PC (with USB port). In this manner, all data from the PV inverter can be evaluated by the "Watch-SOL Software".

	CRSZ-00/03	104932	1
--	------------	--------	---

RF03107

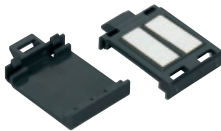

Design	Type designation	Article No.	Units per package
--------	------------------	-------------	-------------------

DIN-rail-clip

- The energy sensor (with or without external sensor) can be attached to the "DIN-rail-clip" in order to snap this combination onto any possible DIN-rail. Note: Do not use metal distribution boards under any circumstances since metal can block the radio signal!!!

Info: **The price and the order number refer to one "DIN-rail-clip" unit.** We cannot deliver single units! Therefore, please order at least one package (10 units) or a multiple thereof.

	CMMZ-00/30	135529	10
--	------------	--------	----



PV inverter grid connected indoors ISG11

- Field of application:
For use with mono- and polycrystalline PV modules to build up a photovoltaic system
- Transformerless design
- High efficiency
- Fanless design keeps the device clean
- ENS acc. to VDE 0126-1-1 integrated
- RCMU acc. to VDE 0126-1-1 integrated
- Application acc. to IEC 60364-7-712 and IEC 62548*)

Connection diagram

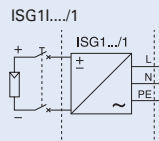

Technical Data

		ISG11-1500/1	ISG11-2000/1	ISG11-2800/1	ISG11-3300/1	ISG11-4000/1
Electrical						
DC	Max. DC power	1760 W	2320 W	3180 W	3820 W	4630 W
	Max. DC voltage	450 VDC	500 VDC	500 VDC	500 VDC	500 VDC
	MPP voltage range	150-405 VDC	150-450 VDC	150-450 VDC	150-450 VDC	150-450 VDC
	Nominal DC voltage	360 VDC	400 VDC	400 VDC	400 VDC	400 VDC
	Max. input current	8.9 ADC	10 ADC	13 ADC	17 ADC	20 ADC
	MPPTracker	1	1	1	1	1
AC	Output power	1500 W	2000 W	2800 W	3300 W	4000 W
	Max. output power	1650 W	2200 W	3000 W	3600 W	4400 W
	Operating voltage	190-256 VAC	190-256 VAC	190-256 VAC	190-256 VAC	190-256 VAC
	Operating frequency	50 Hz	50 Hz	50 Hz	50 Hz	50 Hz
	Current THD	~ 3%	~ 3%	~ 3%	~ 3%	~ 3%
	Power factor	< 1	< 1	< 1	< 1	< 1
Power connection		1-phase	1-phase	1-phase	1-phase	1-phase
SYSTEM	Max. efficiency	> 95%	> 96%	> 96%	> 96%	> 96%
	Euro efficiency	> 94%	> 95%	> 95%	> 95%	> 95%
	Stand-by power	≤ 7 W	≤ 7 W	≤ 7 W	≤ 7 W	≤ 7 W
	Overvoltage category	III	III	III	III	III
	Degree of protection	IP43	IP43	IP43	IP43	IP43
	Operating temperature	-20°C to +55°C	-20°C to +55°C	-20°C to +55°C	-20°C to +55°C	-20°C to +55°C
	Humidity (non-condensing)	0-95%	0-95%	0-95%	0-95%	0-95%
	Acoustic noise level	< 35 dBA	< 35 dBA	< 35 dBA	< 35 dBA	< 35 dBA
Comm. interface		RS232 (RS485 optional)				
Display		LCD / 1 line, 16 characters				
Mechanical						
W x H x D [mm]		326x270x130	360x303x130	360x303x145	447x389x146	447x389x146
T1 [mm]		340	373	373	459	459
Weight [kg]		9.2	11.5	12.5	16.4	16.4

Dimensions (mm)

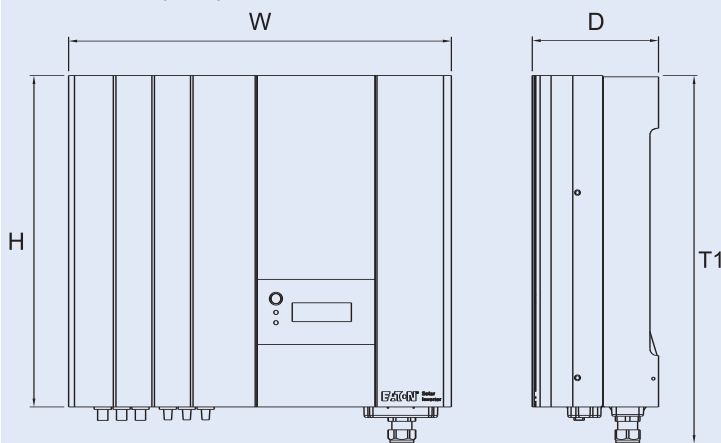

Explanation:

THD Total Harmonic Distortion
*) in preparation



PV inverter grid connected outdoors ISG.O

- Field of application:
For use with mono- and polycrystalline PV modules to build up a photovoltaic system
- Transformerless design
- High efficiency
- Fanless design keeps the device clean
- ENS acc. to VDE 0126-1-1 integrated
- RCMU acc. to VDE 0126-1-1 integrated
- Application acc. to IEC 60364-7-712 and IEC 62548*)

Connection diagrams

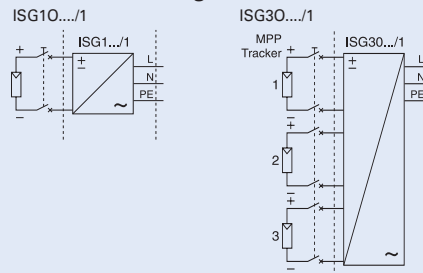

Technical Data

		ISG10-4000/1	ISG30-4600/1
Electrical			
DC	Max. DC power	4630 W	3800 W per tracker
	Max. DC voltage	500 VDC	750 VDC
	MPP voltage range	150-450 VDC	125-700 VDC
	Nominal DC voltage	400 VDC	600 VDC
	Max. input current	20 ADC	8.5 ADC per tracker
	MPP Tracker	1	3
AC	Output power	4000 W	4600 W
	Max. output power	4400 W	5000 W
	Operating voltage	190-256 VAC	190-256 VAC
	Operating frequency	50 Hz	50 Hz
	Current THD	~ 3%	~ 3%
	Power factor	< 1	< 1
Power connection		1-phase	1-phase
SYSTEM	Max. efficiency	> 96%	> 96%
	Euro efficiency	> 95%	> 94.5%
	Stand-by power	≤ 7 W	≤ 8 W
	Overvoltage category	III	III
	Degree of protection	IP65	IP65
	Operating temperature	-20°C to +55°C	-20°C to +55°C
	Humidity (non-condensing)	0-95%	0-95%
	Accoustic noise level	< 35 dBA	< 35 dBA
	Comm. interface	RS232 (RS485 optional)	RS232 (RS485 optional)
	Display	LCD / 1 line, 16 characters	LCD / 2 lines, 32 characters
Mechanical			
W x H x D [mm]		447x389x146	442x532x134
T1 [mm]		459	602
Weight [kg]		19.5	27

Dimensions (mm)

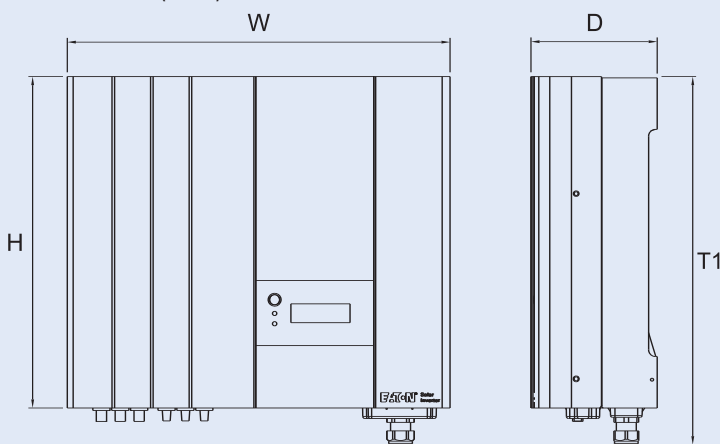

Explanation:

THD Total Harmonic Distortion
*) in preparation

Photovoltaic - DC Disconnection

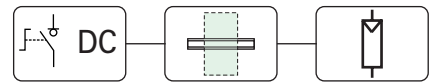

DC Switch-disconnector P-SOL

- Field of application:
DC disconnection in photovoltaic systems between PV array and inverter to switch off the energy
- No polarity
- Any mounting position
- Spring work contacts
- Tested according to IEC/EN 60947-3, UL508
- Certificate TÜV-Rheinland

Connection diagram

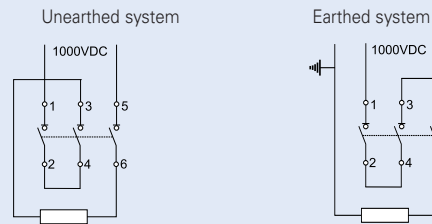

Technical Data

	P-SOL20	P-SOL30	P-SOL60
Electrical			
Number of poles	2	2	2
Rated operational voltage U_e	1000 VDC	1000 VDC	1000 VDC
Rated operational current I_e	20 A	30 A	63 A
Rated short-circuit making capacity I_{cm}	500 A	500 A	1500 A
Rated short-time withstand current 1sec. I_{cw}	700 A	700 A	1500 A
Utilization category	DC-21 A	DC-21 A	DC-21 A
Overvoltage category	III	III	III
Rated impulse withstand voltage U_{imp}	8 kV	8 kV	8 kV
Operating cycles electrical at U_e and I_e	1500	1500	1500
Internal resistance	6 mΩ	5 mΩ	3 mΩ
Mechanical			
Width	58	58	55
Height	93	93	140
Depth	76	76	160
Weight	265 g	265 g	920 g
Mounting quick fastening on DIN rail acc. to IEC/EN 60517	35 mm	35 mm	35 mm
Screw fastening			2xM4x18
Degree of protection	IP20	IP20	IP20
Terminal capacity Flexible with end sleeve	2x (1-6)	2x (1-6)	2x (1-35)
AWG	18-10	18-10	14-2
Tightening torque of terminal screws	1.7 Nm	1.7 Nm	3 Nm
Ambient temperature range	-25°C to +60°C	-25°C to +60°C	-25°C to +60°C
Climatic resistance acc. to IEC 60068-2-78	Damp heat, constant		
acc. to IEC 60068-2-30	Damp heat, cyclic		
Pollution degree	2	2	2
Operating cycles mechanical	100,000	100,000	100,000
Operating cycles mechanical per hour	≤120	≤120	≤120

Dimensions (mm)

P-SOL20
P-SOL30

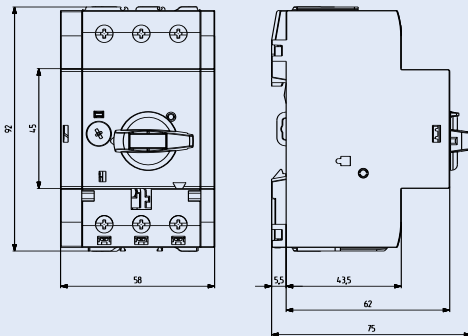

P-SOL60

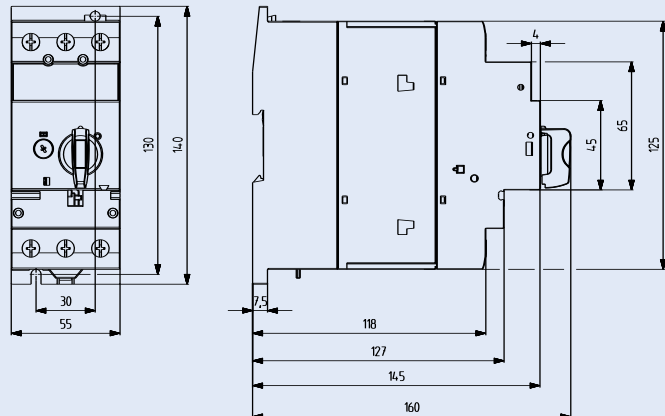

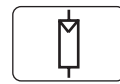
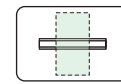
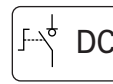

DC Switch-disconnector SOL30-Safety

- Field of application: :
DC disconnection in photovoltaic systems between PV array and inverter to switch off the energy
- Remote release by undervoltage release 230V, 50Hz
- Feedback of the switching status by auxiliary contacts
1 NO and 1 NC
- Pre-wired unit ready for connection
- Lock-able in OFF-position with a padlock
- Any mounting position
- Spring work contacts
- Application acc. to IEC/EN 60947-3

Technical Data

SOL30-SAFETY

Electrical

Number of poles	2
Rated operational voltage U_e	1000 VDC
Rated operational current I_e	30 A
Rated short-circuit making capacity I_{cm}	500 A
Rated short-time withstand current 1sec. I_{cw}	700 A
Utilization category	DC-21 A
Overvoltage category	III
Rated impulse withstand voltage U_{imp}	8 kV
Operating cycles electrical at U_e and I_e	1500
Internal resistance	5 m Ω

Mechanical

Weight	470 g
Degree of protection	IP65
Ambient temperature range	-25°C to +60°C
Climatic resistance acc. to 60068-2-78	Damp heat, constant
acc. to 60068-2-30	Damp heat, cyclic
Pollution degree	3
Operating cycles mechanical	100,000
Operating cycles mechanical per hour	≤120

Dimensions (mm)

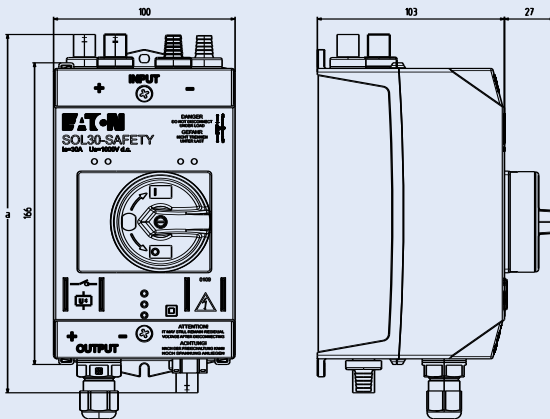

SOL30-Safety	a [mm]
MC3	197
MC4	234
MV	224

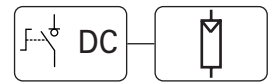

DC Switch-disconnector SOL as pre-wired unit

- Field of application:
DC disconnection in photovoltaic systems between PV array and inverter to switch off the energy
- Pre-wired unit ready for connection
- Lock-able in OFF-position with a padlock
- Any mounting position
- Spring work contacts
- Tested according to IEC/EN 60947-3, UL508
- Certificate TÜV-Rheinland

Connection diagram

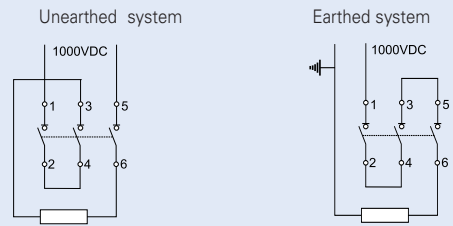

Technical Data

	SOL20	SOL30
Electrical		
Number of poles	2	2
Rated operational voltage U_e	1000 VDC	1000 VDC
Rated operational current I_e	20 A	30 A
Rated short-circuit making capacity I_{cm}	500 A	500 A
Rated short-time withstand current 1sec. I_{cw}	700 A	700 A
Utilization category	DC-21 A	DC-21 A
Overvoltage category	III	III
Rated impulse withstand voltage U_{imp}	8 kV	8 kV
Operating cycles electrical at U_e and I_e	1500	1500
Internal resistance	8 m Ω	7 m Ω

Mechanical

Weight	420 g	420 g
Degree of protection	IP65	IP65
Terminal capacity with / without end sleeve AWG		
Ambient temperature range	-25°C to +60°C	-25°C to +60°C
Climatic resistance acc. to 60068-2-78 acc. to 60068-2-30	Damp heat, constant	Damp heat, cyclic
Pollution degree	3	3
Operating cycles mechanical	100,000	100,000
Operating cycles mechanical per hour	≤120	≤120

Dimensions (mm)

SOL20(30)	a [mm]
MC4	234
MV	224

SOL20
SOL30

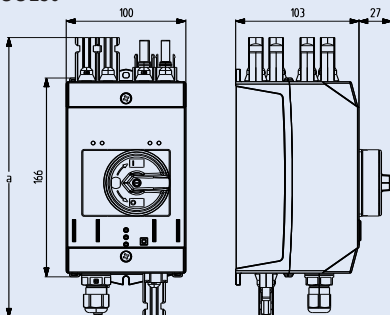

SOL20/2MC4
SOL30/2MC4

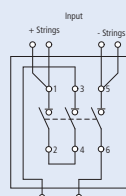

SOL20/2MV
SOL30/2MV

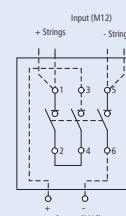

SOL20/4MC4
SOL30/4MC4

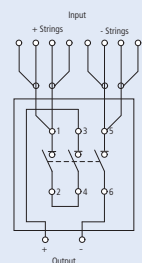

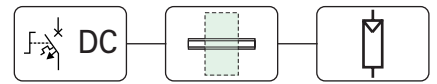

DC string circuit-breaker PKZ-SOL

- Field of application:
DC circuit-breaker for string protection in photovoltaic systems
- No polarity
- Spring work contacts
- Tested according to IEC/EN 60947-2
- Certificate TÜV-Rheinland

Connection diagram

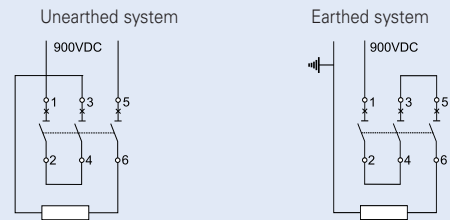

Technical Data

PKZ-SOL4
PKZ-SOL7
PKZ-SOL12
PKZ-SOL20
PKZ-SOL30

Electrical

Number of poles	2
Rated operational voltage U_e	900 VDC
Rated current I_n	4 / 7 / 12 / 20 / 30 A
Thermal tripping characteristic	1.05 to 1.3 x I_n
Electromagnetic tripping characteristic	6 x I_n
Rated ultimate short-circuit breaking capacity I_{cu}	5 kA
Rated service short-circuit breaking capacity I_{cs}	1.5 kA
Overvoltage category	III
Rated impulse withstand voltage U_{imp}	8 kV
Operating cycles electrical at U_e and I_n	1500
Internal resistance	138 / 60 / 32 / 14 / 9 m Ω

Mechanical

Width	58
Height	93
Depth	76
Weight	265 g
Mounting quick fastening on DIN rail acc. to IEC/EN 60517	35 mm
Screw fastening	
Degree of protection	IP20
Terminal capacity Flexible with end sleeve mm ²	2x (1-6)
AWG	18-10
Tightening torque of terminal screws	1.7 Nm
Ambient temperature range	-25°C to +60°C
Climatic resistance acc. to IEC 60068-2-78	Damp heat, constant
acc. to IEC 60068-2-30	Damp heat, cyclic
Pollution degree	2
Operating cycles mechanical	100,000
Operating cycles mechanical per hour	≤120

Mounting position

PKZ-SOL4
PKZ-SOL7
PKZ-SOL12
PKZ-SOL20
PKZ-SOL30

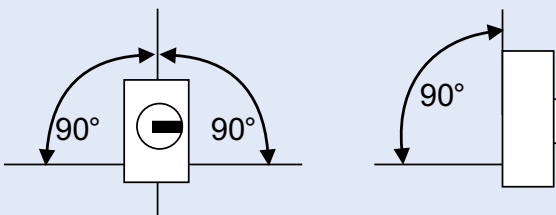

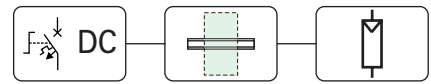

DC string circuit-breaker PKZ-SOL

Characteristic curve setting value - short-circuit-current

According to the design for IEC 62548-1, the tripping current for the circuit-breaker must fall within a range of 1.4 to 2 times the value of the short-circuit current of the PV modules, in order to protect the PV modules.

Since only the current values for the built-in overload tripping device can be plotted on the setting scale of the circuit breaker¹⁾, the correlation between the tripping current for the safety device and the short-circuit current for the PV modules must be properly indicated for every point of the scale.

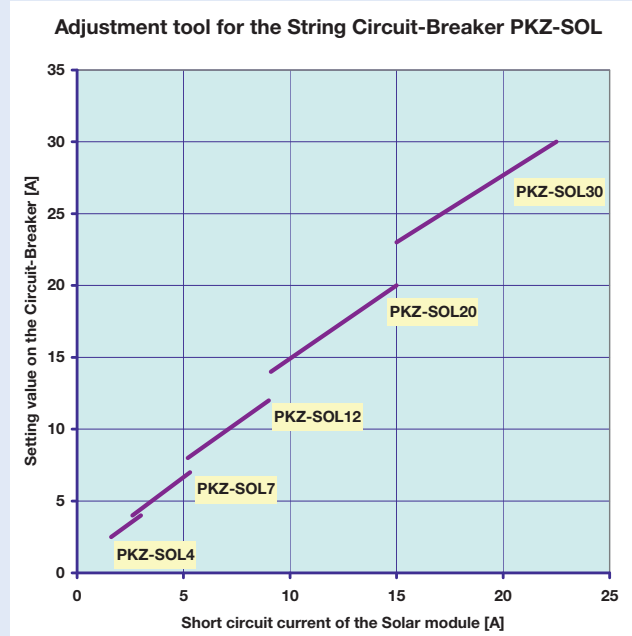
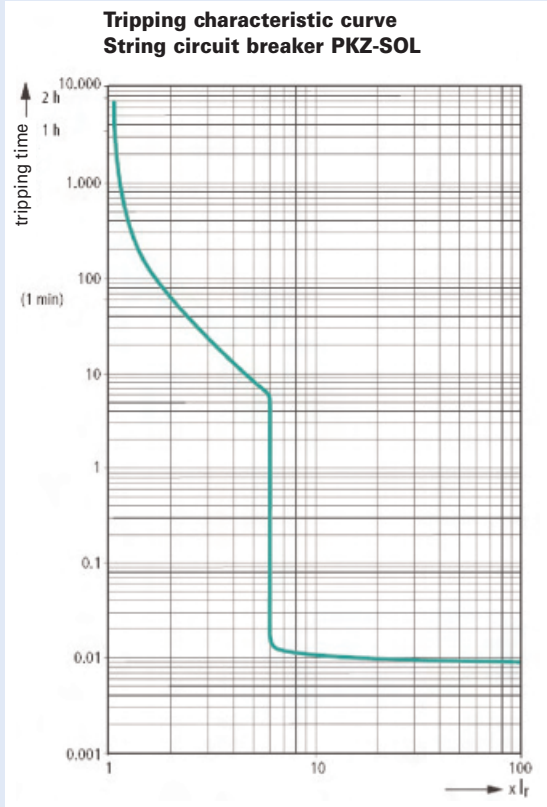

¹⁾ Norm IEC/EN 60947-2 (section 4.7.3) prohibits a direct specification of the PV short-circuit current on the circuit-breaker's setting scale, whereby only the setting value for the response current may be entered.

Dimensions (mm)

- PKZ-SOL4
- PKZ-SOL7
- PKZ-SOL12
- PKZ-SOL20
- PKZ-SOL30

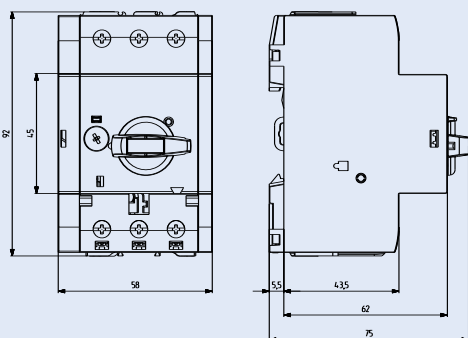



Fuse-disconnector FCDC10DI...SOL

- Design according to IEC 60947-1 Ed. 4.0, EN 60947-1:1999+A1:2000+A2:2001 IEC 60947-3 Ed. 2.1, EN 60947-3:1999+A1:2001
- Types L with visual tripping indicator
- Suitable for cylindrical fuse-links photovoltaic application 10x38 according to IEC 60269, UL284-4
- Can be sealed with lead
- Supplied without fuse-links

Technical Data

Electrical

Number of poles	1P, 2P
Rated voltage U_e	1000 V DC
Rated current I_e	25 A
Rated conditional short-circuit current	10 kA
Utilization category	DC 20 B
Rated insulation voltage U_i	1000 V DC
Overvoltage category	III
Rated impulse withstand voltage U_{imp}	6 kV
Power loss per current path without fuse-link	0.9 W
Maximum permissible power loss of fuse-links	3 W

Mechanical

Frame size	45 mm
Device height	83.3 mm
Device width	17.5 mm per pole
Weight	
1P	58 g
2P	70 g
Mounting	Quick fastening on DIN rail IEC/EN 60715
Degree of protection	IP20
Terminals above and below	lift terminals
Terminal capacity	0.5 - 10 mm ²
	AWG 20-8
Tightening torque of terminal screws	1.2 Nm
Ambient temperature range	-25 to +40°C
Flame class	glow wire tested 960°C
Pollution degree	2
Comparative tracking index	CTI 450

Dimensions (mm)

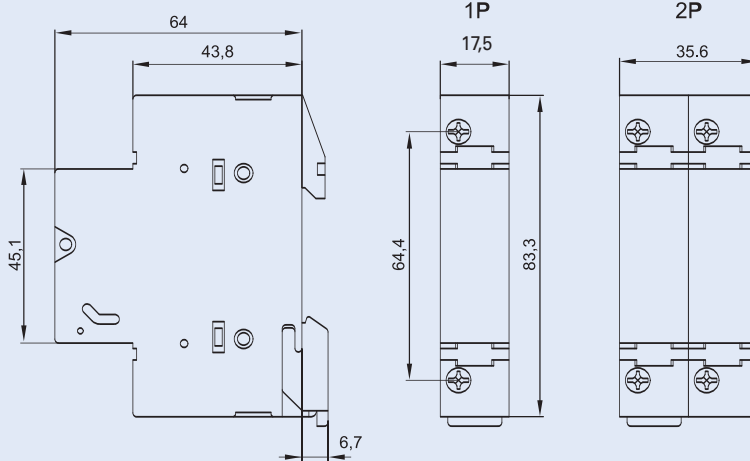

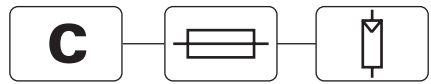

Fuse-Links ASFLC10-..A-gPV-SOL photovoltaic application

- According to IEC 60269-1 and IEC 60269-4
- For fuse-switch-disconnectors FCFDC10DI

Connection diagram



Technical Data

Electrical

ASFLC10-..A-gPV-SOL 10x38

Rated voltage U_n	6 - 20 A / 1000 V DC 25 A / 900 V DC
Rated frequency	-
Rated short-circuit breaking capacity	30 kA
$\tau = L/R$	2 ms

Max. Power dissipation

Rated current I_n	Pre-arcing Joule integral $L/R = 2$ ms	Operating Joule integral $L/R = 2$ ms	Power dissipation at $0.7 \times I_n$	Power dissipation at I_n P_d [W]	Weight P_d [g]
[A]	[A ² s]	[A ² s]	[W]	[W]	[g]
2	1.3	3.5	1.47	1.00	10
4	3.3	28	0.52	1.25	10
6	5.5	45	0.73	1.65	10
8	8	62	0.93	1.9	10
10	11	88	1.06	2.3	10
12	23	180	1.03	1.9	10
16	35	270	1.00	2.5	10
20	50	430	1.18	3.25	10
25	75	620	1.25	3.45	10

Dimensions (mm)

Type	Size	a	$b_{max.}$	c	$d_{min.}$	r
ASFLC10	10x38	38.0±0.6	10.5	10.3±0.1	6	1.5±0.5

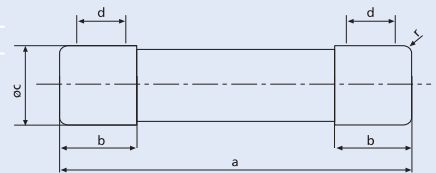

Characteristics ASFLC10-..A-gPV-SOL, photovoltaic application

Time/current characteristics of ASFLC10-..A-gPV-SOL Fuse-links 2 ... 25A

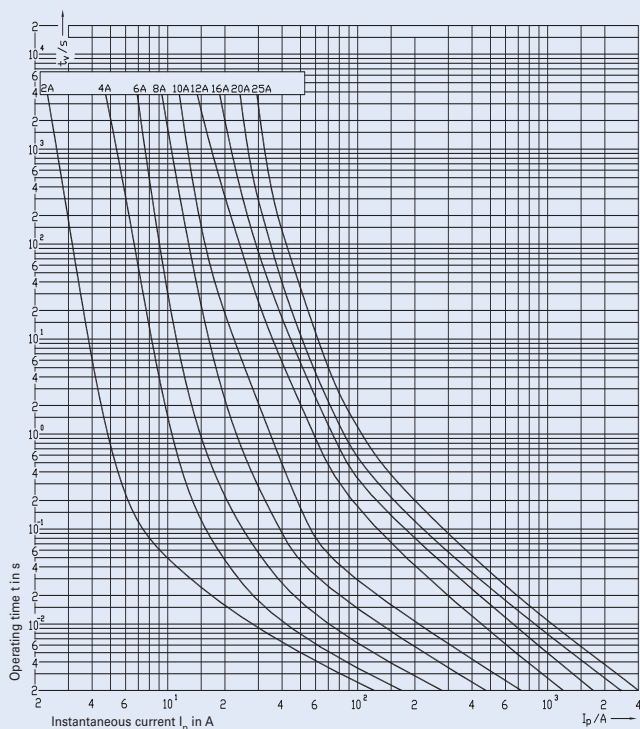

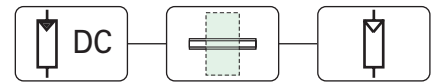

SPD-type T2 (Class C), plug-in surge arresters SPPT2PA-...-2PE

- Field of application:
For the protection of photovoltaic systems against transient overvoltage caused by indirect lightning strike and switching operations.
- Test class **II** according to IEC 61643-1
- SPD-type **T2** according to EN 61643-11
- Types SPPT2PA-...-AX for remote message transmission of defective inserts

Connection diagrams

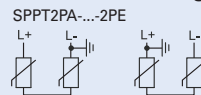

Technical Data

	SPPT2PA-600-2PE	SPPT2PA-1000-2PE(-AX)
Electrical		
Response time	≤ 25 ns	≤ 25 ns
Maximum continuous operating voltage U_C	600 V DC	1000 V DC
Rated frequency	DC	DC
Nominal discharge current I_n	15 kA (8/20) μ s	15 kA (8/20) μ s
Voltage protection level U_p	≤ 3 kV	≤ 5 kV
Residual voltage at 5 kA (8/20) μ s	≤ 2.5 kV	≤ 4 kV
Maximum discharge current I_{max}	30 kA (8/20) μ s	30 kA (8/20) μ s
Permissible back-up fuse	-	-
Maximum short-circuit current I_{sc}	80 A	80 A
Residual current I_{PE}	≤ 20 μ A	≤ 20 μ A
Mechanical		
Frame size	45 mm	45 mm
Device height	90 mm	90 mm (99 mm)
Device width	35.6 mm	35.6 mm
Weight	247 g	247 g (249 g)
Upper and lower lift terminal capacity stranded / solid core	4-25/4-35 mm ² /AWG11-2	4-25/4-35 mm ² /AWG11-2
Tightening torque of terminal screws	4.5 Nm	4.5 Nm
Permitted ambient temperature	-40°C up to +80°C	-40°C up to +80°C
Mounting	quick fastening on DIN rail IEC/EN 60715	
Degree of protection	IP20	IP20
Polution degree	2	2

Auxiliary switch

Electrical	
Rated insulation voltage	250 V
Rated frequency	50/60 Hz
Switching contact	1 CO
Minimum voltage per contact	5 V AC/DC
Rated operational current	1.5 A / 250 V AC 1.5 A / 30 V DC
Min. admissible power	5 mA / 5 V

Mechanical

Terminal capacity stranded / solid core	1.5/1.5 mm ² /AWG28-18
Tightening torque of terminal screws	0.25 Nm

Dimensions (mm)

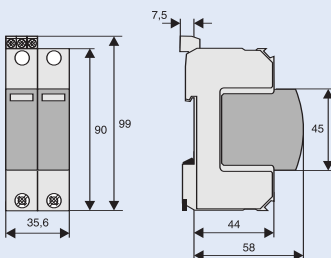

Application hints according to EN 50539-12

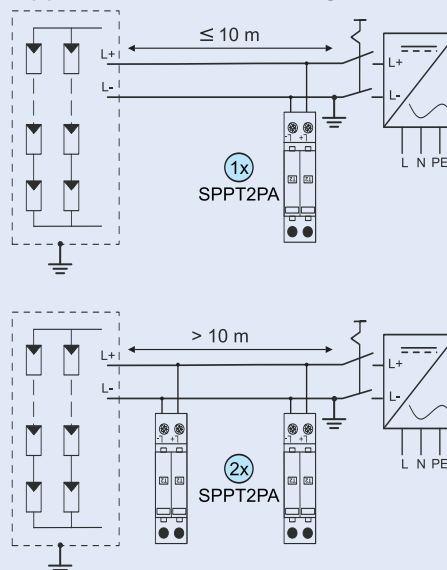

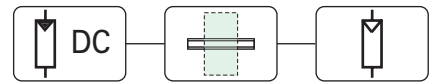

SPD-type T2 (Class C), plug-in surge arresters SPPT2PA-...-2+1PE

- Field of application:
For the protection of photovoltaic systems against transient overvoltage caused by indirect lightning strike and switching operations.
- Test class **II** according to IEC 61643-1
- SPD-type **T2** according to EN 61643-11
- Galvanic isolation in unearthed systems by means of a spark gap
- Types SPPT2PA-...-AX for remote message transmission of defective inserts

Connection diagrams

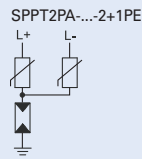

Technical Data

		SPPT2PA-600-2+1PE	SPPT2PA-1000-2+1PE(-AX)
Electrical			
Response time	L+ -> L- / L- -> PE	≤ 25 ns / ≤ 100 ns	≤ 25 ns / ≤ 100 ns
Maximum continuous operating voltage U_C		600 V DC	1000 V DC
Rated frequency		DC	DC
Nominal discharge current I_n		15 kA (8/20) μ s	15 kA (8/20) μ s
Voltage protection level U_p	L+ -> L- / L- -> PE	≤ 3 kV / ≤ 3 kV	≤ 5 kV / ≤ 3 kV
Residual voltage at 5 kA (8/20) μ s	L+ -> L- / L- -> PE	≤ 2.5 kV / ≤ 2 kV	≤ 4 kV / ≤ 2 kV
Maximum discharge current I_{max}		30 kA (8/20) μ s	30 kA (8/20) μ s
Permissible back-up fuse		-	-
Maximum short-circuit current I_{sc}		80 A	80 A
Residual current I_{PE}		≤ 20 μ A	≤ 20 μ A
Mechanical			
Frame size		45 mm	45 mm
Device height		90 mm	90 mm (99 mm)
Device width		53.4 mm	53.4 mm
Weight		318 g	318 g (323 g)
Upper and lower lift terminal capacity stranded / solid core		4-25/4-35 mm ² /AWG11-2	4-25/4-35 mm ² /AWG11-2
Tightening torque of terminal screws		4.5 Nm	4.5 Nm
Permitted ambient temperature		-40°C up to +80°C	-40°C up to +80°C
Mounting		quick fastening on DIN rail IEC/EN 60715	
Degree of protection		IP20	IP20
Polution degree		2	2

Auxiliary switch

Electrical	
Rated insulation voltage	250 V
Rated frequency	50/60 Hz
Switching contact	1 CO
Minimum voltage per contact	5 V AC/DC
Rated operational current	1.5 A / 250 V AC
	1.5 A / 30 V DC
Min. admissible power	5 mA / 5 V

Mechanical	
Terminal capacity stranded / solid core	1.5/1.5 mm ² /AWG28-16
Tightening torque of terminal screws	0.25 Nm

Dimensions (mm)

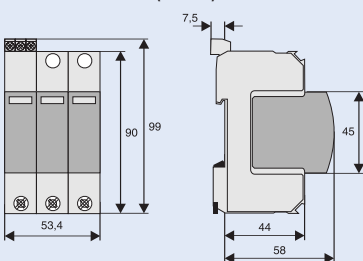

Application hints according to EN 50539-12

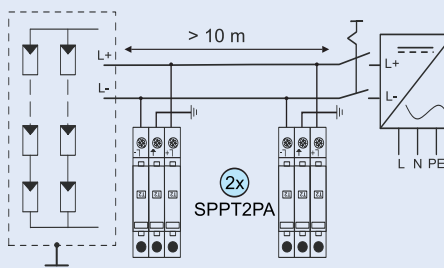
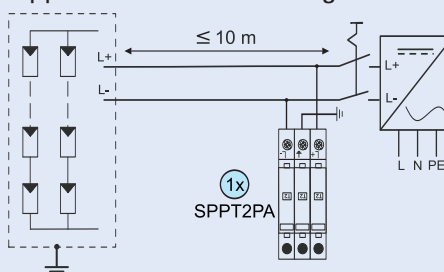



SPD-Type T2 (Class C), PV surge protection device SOL-SP as a pre-wired unit

- Field of application:
For the protection of photovoltaic systems against transient overvoltage caused by indirect lightning strike and switching operations.
- Test class II according to IEC 61643-1
- SPD-type T2 according to EN 61643-11
- Galvanic isolation in unearthed systems by means of a spark gap

Connection diagram

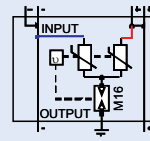

Technical Data

		SOL-SP600	SOL-SP1000
Electrical			
Responding time	L+ -> L- / L- -> PE	≤ 25 ns / ≤ 100 ns	≤ 25 ns / ≤ 100 ns
Maximum continuous operating voltage U_C		600 V DC	1000 V DC
Rated frequency		DC	DC
Nominal discharge current I_n		15 kA (8/20) μ s	15 kA (8/20) μ s
Voltage protection level U_p	L+ -> L- / L- -> PE	≤ 3 kV / ≤ 3 kV	≤ 5 kV / ≤ 3 kV
Residual voltage at 5 kA (8/20) μ s	L+ -> L- / L- -> PE	≤ 2.5 kV / ≤ 2 kV	≤ 4 kV / ≤ 2 kV
Maximum discharge current I_{max}		30 kA (8/20) μ s	30 kA (8/20) μ s
Permissible back-up fuse		-	-
Maximum short-circuit current I_{sc}		80 A	80 A
Residual current I_{PE}		≤ 20 μ A	≤ 20 μ A
Rated operational voltage U_e		600 VDC	1000 VDC
Rated operational current I_e	MC3, MC4 M16	30 A 32 A	30 A 32 A
Mechanical			
Weight		420 g	420 g
Degree of protection		IP65	IP65
Terminal capacity	+,- without end sleeve AWG	6 mm ² 10	6 mm ² 10
	PE stranded / flexible AWG	4-25 / 4-35 mm ² 11-2	4-25 / 4-35 mm ² 11-2
Tightening torque of terminal screws	+,- PE		3 Nm 3 Nm 4.5 Nm 4.5 Nm
Permitted ambient temperature		-40°C to +60°C	-40°C to +60°C
Pollution degree		3	3

Dimensions (mm)

SOL-SP	a [mm]
MC3	197
MC4	234
MV	224

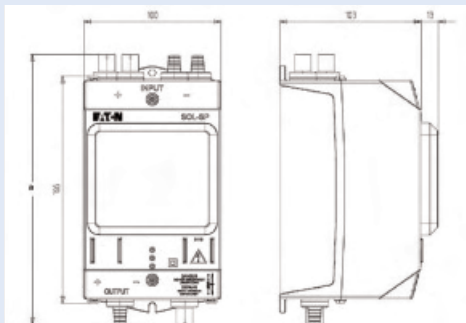

Connection example

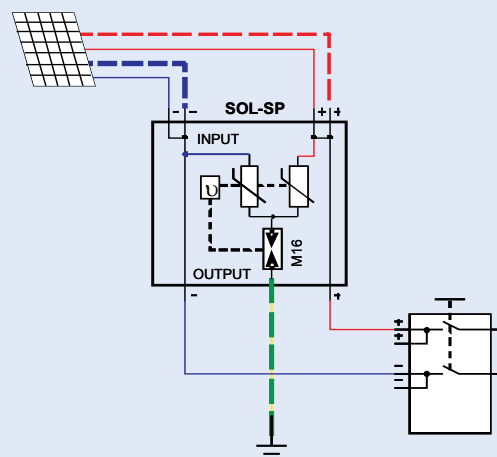

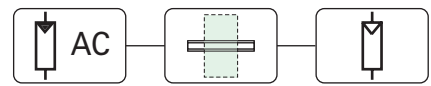



SPD-Type T2 (Class C), plug-in surge arresters SPMT2PA

- Field of application:
For the protection of photovoltaic systems against transient overvoltage caused by indirect lightning strike and switching operations.
- Test class **[II]** according to IEC 61643-1
- SPD-type **[T2]** according to EN 61643-11
- Types SPMT2PA-...-AX for remote message transmission of defective inserts
- Busbar connection to EATON switchgears

Connection diagram



Technical Data

Inserts	SPMT2PA -280	-335	-NPE
Electrical			
SPD-type	[T2] [T3]	[T2] [T3]	[T2] [T3]
Mechanical coding	x	x	y
Responding time	< 25 ns	< 25 ns	< 100 ns
Voltage protection level at nominal discharge current / U_{oc}	< 1.4 kV	< 1.6 kV	< 1.5 kV
Voltage protection level at 5 kA (8/20) μ s	1000 V	1200 V	-
Maximum continuous operating voltage U_c	280 VAC	335 VAC	260 VAC
Temporary overvoltage test value U_T	350 VAC (5s)	415 VAC (5s)	12000 VAC (200ms)
Rated frequency	50/60 Hz	50/60 Hz	50/60 Hz
Open circuit voltage U_{oc}	10 kV	10 kV	5 kV
Nominal discharge current (8/20) μ s I_n	20 kA	20 kA	40 kA
Charge Q at I_n	0.57 As	0.57 As	1.14 As
Specific energy at I_n	5.7 kJ/ Ω	5.7 kJ/ Ω	22.8 kJ/ Ω
Maximum discharge current I_{max}	40 kA	40 kA	60 kA
Follow current interrupt rating I_{fi}	-	-	-
Permissible back-up fuse	 ≤ 160 AgL	 mMCT-C100	-
Maximum short-circuit current	50 kA _{r.m.s.}	20 kA _{r.m.s.}	-

Connection diagram

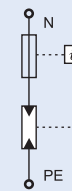
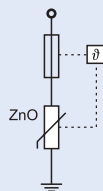

Mechanical

Frame size	45 mm
Device height	80 mm
Device width	17.5 mm per pole
Weight base 1P, 1+1P, 2P, 3P, 3+1P, 4P	53/120/120/180/240/240 g
Weight complete devices 1P, 1+1P, 2P, 3P, 3+1P, 4P	110/201/220/330/412/440 g
Permitted ambient temperature	-40°C to +70°C
Degree of protection (built-in)	IP40
Upper and lower lift terminal capacity	4 - 25 mm ²
Upper and lower open mouthed terminals for busbar thickness up to	1.5 mm
Tightening torque of terminal screws	2.4 - 3 Nm
Quick fastening on DIN rail according to	IEC/EN 60715

Dimensions (mm)

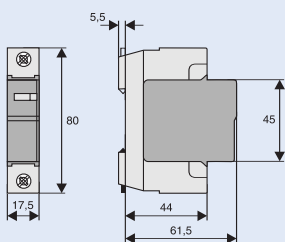

Application Examples SPMT2PA according to IEC 60364-5-53 Clause 534

TN-C-System
3 x 240/415 VAC
3 x 230/400 VAC
3 x 220/380 VAC

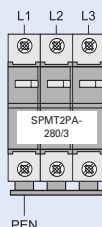

TN-S-System
3 x 240/415 VAC
3 x 230/400 VAC
3 x 220/380 VAC

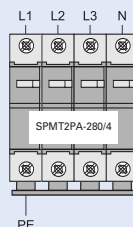

TN-S/TT-System
3 x 240/415 VAC
3 x 230/400 VAC
3 x 220/380 VAC

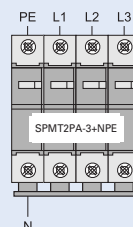

TN-S/TT-System
3 x 240/415 VAC
3 x 230/400 VAC
3 x 220/380 VAC

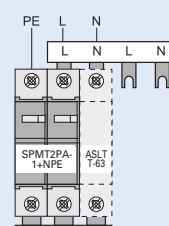

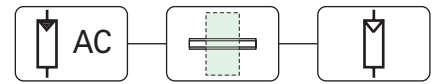

SPD-type 2 (Class C), surge arresters SPMT2PA-1+NPE, SPMT2PA-3+NPE

- Field of application:
For the protection of low voltage distribution systems against transient overvoltage caused by indirect lightning strike and switching operations.
- Test class II according to IEC 61643-1
- SPD-type T2 according to EN 61643-11
- Auxiliary switch ASAXSC-SPM for remote message transmission can be mounted onto the device
- Suitable for busbar connection to EATON switchgear
- Type **SPMT2PA-3+NPE**:
consists of 1 base,
1 insert SPMT2PA-NPE and 3 inserts SPMT2PA-335
- Type **SPMT2PA-1+NPE**:
consists of 1 base,
1 insert SPMT2PA-NPE and 1 insert SPMT2PA-335

Technical Data

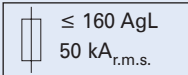
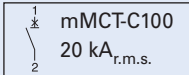
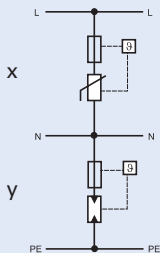
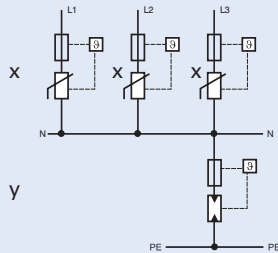
	SPMT2PA-1+NPE	SPMT2PA-3+NPE
Electrical		
SPD-type	T2 T3	T2 T3
Mechanical coding	yx	yxxx
Response time	L-N/N-PE/L-PE < 25ns/< 100ns/< 100ns	< 25ns/< 100ns/< 100ns
Maximum continuous operating voltage U_c	L-N/N-PE 335VAC/260VAC	335VAC/260VAC
Temporary overvoltage test value U_T (5 s) (200 ms)	L-N 415 VAC N-PE 1200 VAC	415 VAC 1200 VAC
Rated frequency	50/60 Hz	50/60 Hz
Nominal discharge current I_n	L-N/N-PE/L-PE 20 kA (8/20) μ s	20 kA (8/20) μ s
Voltage protection level U_p at I_n	L-N/N-PE/L-PE $\leq 1600V/\leq 1500V/\leq 2050V$	$\leq 1600V/\leq 1500V/\leq 1900V$
Maximum discharge current I_{max}	L-N/N-PE/L-PE 40 kA (8/20) μ s	40 kA (8/20) μ s
Follow current interrupt rating I_{fi}	N-PE 100 A _{r.m.s.}	100 A _{r.m.s.}
Permissible back-up fuse	 ≤ 160 AgL 50 kA _{r.m.s.}	 mMCT-C100 20 kA _{r.m.s.}
Maximum short-circuit current		
Connection diagram		

Mechanical

Mechanical coding of base	yx	yxxx
Frame size	45 mm	45 mm
Device height	80 mm	80 mm
Device width	35 mm	70 mm
Weight	201 g	412 g
Upper and lower lift terminal capacity	1 - 25 mm ²	1 - 25 mm ²
Open-mouthed terminals at both sides for busbar thickness up to	1.5 mm	1.5 mm
Tightening torque of terminal screws	2.4 - 3 Nm	2.4 - 3 Nm
Permitted ambient temperature	-40°C to +70°C	-40°C to +70°C
Mounting	quick fastening on DIN rail IEC/EN 60715	
Degree of protection (built-in)	IP40	IP40

Dimensions (mm)

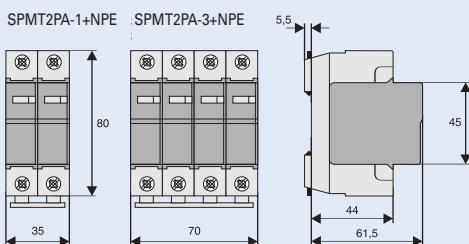

Application Examples

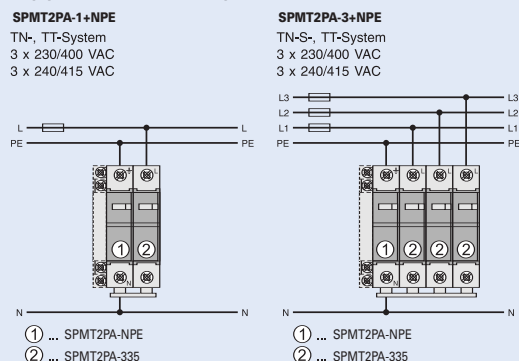

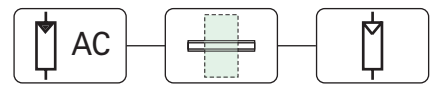

Auxiliary Switch for surge arresters ASAXSC-SPM

- Field of application:
For mounting onto surge protective devices for external defect message transmission
- Design basically in accordance with IEC 60947-5-1
- Can be mounted subsequently
- Suitable for SPMT2PA

Connection diagram

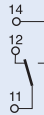

Technical Data

Electrical

Rated insulation voltage	250 V
Rated frequency	50/60 Hz
Switching contact	1 CO
Minimum voltage per contact	24 VAC
Rated operational current AC12	2A/250VAC
Maximum back-up fuse	2 A gL
Overtoltage category	IV
Pollution degree	2

Mechanical

Frame size	45 mm
Device height	80 mm
Device width	8.8 mm
Weight	41 g
Mounting	screw-mounting onto SPMT2PA
Degree of protection, built-in	IP40
Finger and hand touch safe acc. to	BGV A3, ÖVE-EN 6
Upper and lower terminals	lift terminals
Terminal capacity	2 x 2.5 mm ²
Tightening torque of terminal screws	0.8 - 1 Nm

Dimensions (mm)

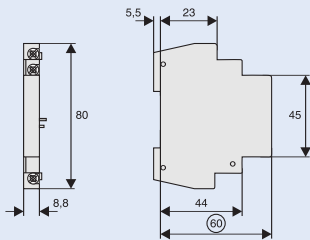

Application examples

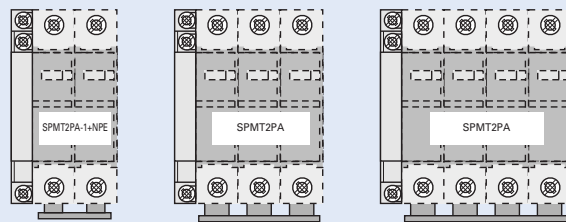

Lead-through terminal for surge protective devices, SPD-type 2 (Class C), ASLTT-63

- The lead-through terminal permits orderly wiring of SPDs types 2 (class C). It serves as lead-through terminal in circuits requiring vertical connections from the upper to the lower SPD connection level.
- 1-pole
- Suitable for standard busbar connection to EATON switchgear

Connection diagram

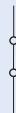

Technical Data

Electrical

Rated voltage	690V AC/DC
Rated current	63 A
Rated frequency	50/60 Hz

Mechanical

Frame size	45 mm
Device height	80 mm
Device width	17.5 mm
Mounting	quick fastening on DIN rail IEC/EN 60715
Degree of protection, built-in	IP40
Finger and hand touch safe acc. to	BGV A3, ÖVE-EN 6
Upper and lower terminals	lift and open-mouthed terminals
Terminal capacity	1 - 25 mm ²
Busbar thickness	0.8 - 2 mm
Tightening torque of terminal screws	2.4 - 3 Nm

Dimensions (mm)

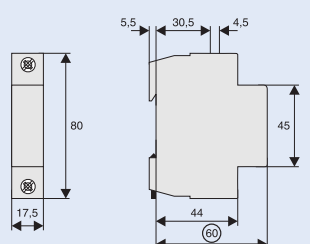

Application Example / Connection type 2 acc. to IEC 60364-5-53 Clause 534

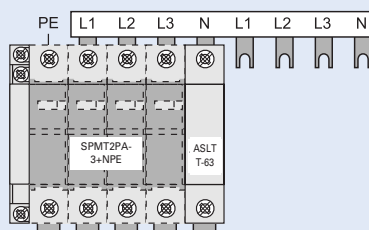

Photovoltaic - Energy Management

Connection example for energy sensor CEMU-01/04

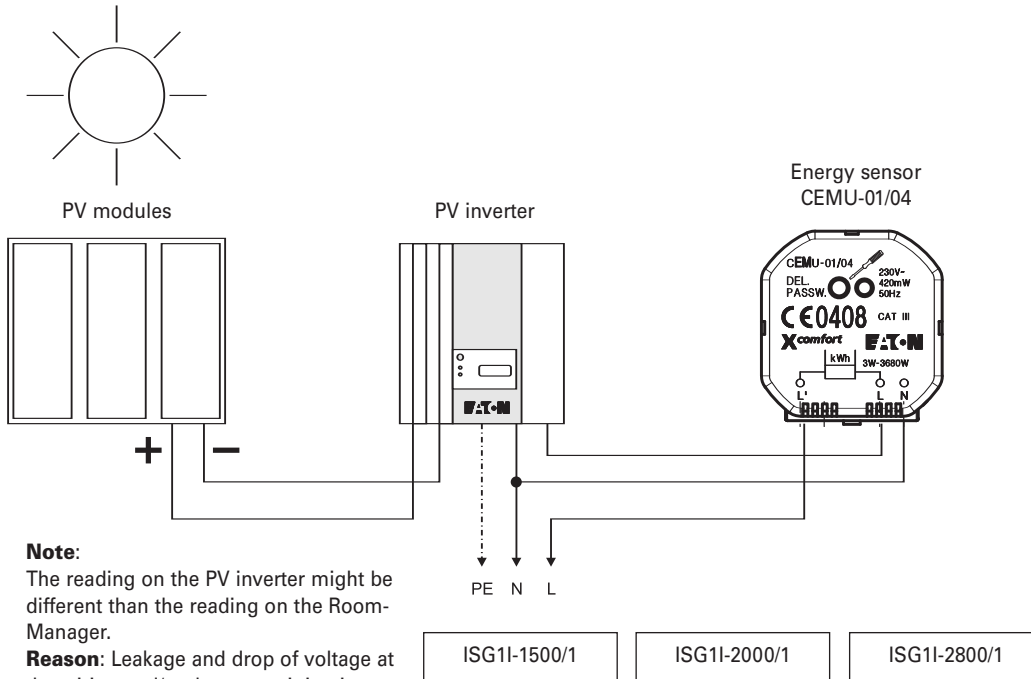

Note:

The reading on the PV inverter might be different than the reading on the Room-Manager.

Reason: Leakage and drop of voltage at the wiring and/or the transmitting intervals from the energy sensor to the Room-Manager and the update intervals at the PV-inverter display.

Connection example for energy sensor CEMU-01/03

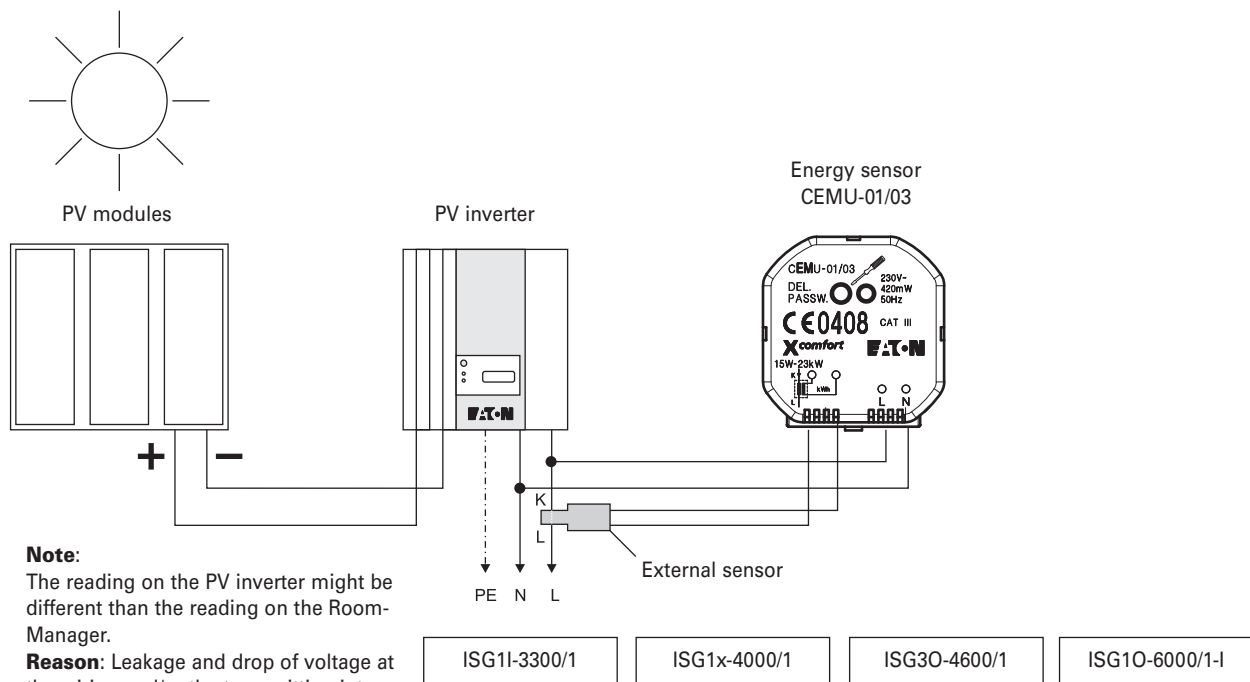

Note:

The reading on the PV inverter might be different than the reading on the Room-Manager.

Reason: Leakage and drop of voltage at the wiring and/or the transmitting intervals from the energy sensor to the Room-Manager and the update intervals at the PV inverter display

Photovoltaic - RF system - Flush-Mounted Devices

Energy sensor CEMU-01/04

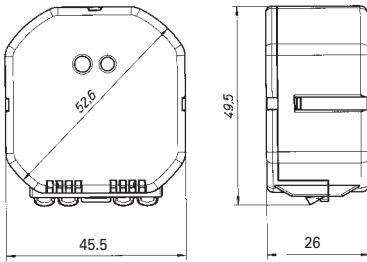

Technical specifications

Power supply	230VAC, 50Hz
Connections	Lead wires solid, 2.5mm ²
Power consumption	0.42VA
Pre-protection	LS 16A, characteristic C
Max. current	16 A
Min. output	>3 W
Max. output	≤3680 W
Accuracy	10%
Measurement units	Energy in Wh, current in A, voltage in V, active power in W
Frequency	868.300 MHz
Type of transmission	Bi-directional, via coded telegrams
Reach inside buildings	typically 15-25 m, 1 wall + 1 ceiling (depending on wall thickness and material!!)
Degree of Protection	IP20
Degree of soiling	2
Operating temperature	-5 to +45°C
Storage and transportation temp.	-25 to +70°C
Enclosure colour	Grey, RAL7035
Enclosure dimensions	HxWxD - 48.6 x 45.3 x 26.2 mm
Length of lead wires	150 mm
Approval:	Printed onto the device

* Information: For technical reasons, the CEMU-01/04 energy meter sensor features a shorter RF range than usual Xcomfort standard products. "Routing" the signal may therefore be necessary in cases where the direct RF range is not sufficient. However, this does not impair the functionality of the energy meter function and will not be accepted as a reason for complaint.

Energy sensor with external sensor CEMU-01/03

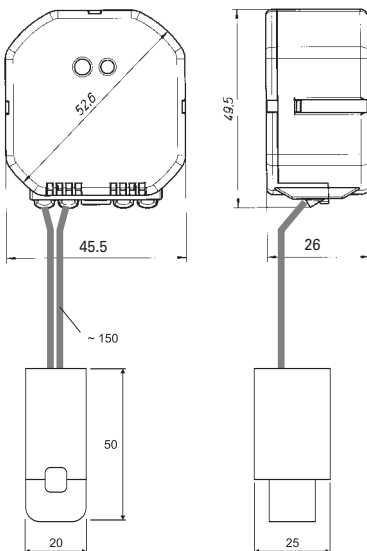

Technical specifications

Power supply	230VAC, 50Hz
Connections	Lead wires solid, 1.5mm ²
Power consumption	0.42VA
Pre-protection	LS 16A, characteristic C
Max. current	16 A
Min. output	>15 W (over external sensor)
Max. output	≤23 W (max. 100A) (over external sensor)
Accuracy	10%
Measurement units	Energy in Wh, current in A, voltage in V, active power in W
Frequency	868.300 MHz
Type of transmission	Bi-directional, via coded telegrams
Reach inside buildings	typically 15-25 m, 1 wall + 1 ceiling (depending on wall thickness and material!!)
Degree of Protection	IP20
Degree of soiling	2
Operating temperature	-5 to +45°C
Storage and transportation temp.	-25 to +70°C
Enclosure colour	Grey, RAL7035
Enclosure dimensions	HxWxD - 48.6 x 45.3 x 26.2 mm
Length of lead wires	150 mm
Approval:	Printed onto the device

* Information: For technical reasons, the CEMU-01/03 energy meter sensor features a shorter RF range than usual Xcomfort standard products. "Routing" the signal may therefore be necessary in cases where the direct RF range is not sufficient. However, this does not impair the functionality of the energy meter function and will not be accepted as a reason for complaint.

Photovoltaic - RF system - Surface-Mounted Devices

Room-Manager CRMA-00/03 to CRMA-00/06 (without Bluetooth)

CRMA-00/02

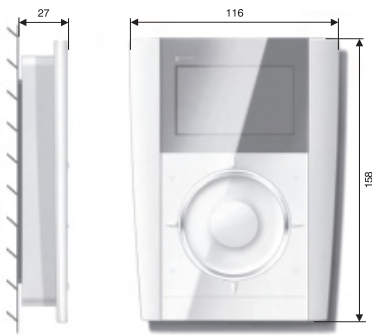

Technical Specifications

Power supply	230VAC / 50Hz
Power consumption	1VA (without Bluetooth)
Pre-protection	LS 16A, characteristic C
Frequency	868.300 MHz
Type of transmission	Bi-directional, via coded telegrams
Indoor range	typically 30-50 m, 2 walls + 1 ceiling (depending on wall thickness and material!!)
Power reserve-time	24 hours
Interfaces	IR interface for system update Eaton RF for configuration/operation
Degree of Protection	IP20
Degree of soiling	2
Operating temperature	+5 to +45°C
Storage and transportation temp.	-25 to +70°C
Enclosure colour	similar to RAL9006
Enclosure dimensions	HxWxD - 158 x 116 x 27 mm
Approval:	Printed onto the device

Connection example for CRMA-00/03 - CRMA-00/06



Eaton Corporation

Eaton is a leading power management company. Eaton operates worldwide with products, systems and services in the electrical, hydraulic, aerospace, truck and automotive sectors.

Eatons Electrical Sector

Eatons Electrical Sector is the worldwide leader in products, systems and services for energy distribution, safe electricity supply and automation in industrial, residential and purpose-built buildings, public facilities, energy providers, commerce and OEMs.

Eaton Electrical Sector includes the brands Cutler-Hammer®, Moeller®, Micro Innovation, Powerware®, Holec®, MEM® and Santak®.

www.eaton.com

E-Mail: info-int@eaton.com
Internet: www.eaton.com/moellerproducts

Publisher:
Eaton GmbH
Eugenia 1
A-3943 Schrems

Eaton Industries GmbH
Hein-Moeller-Str. 7-11
D-53115 Bonn

© 2010 by Eaton Industries GmbH
Subject to alterations
W7400-7622EN ip 03/11
Printed in Germany (03/11)
Article No.: 143181



EATON

Powering Business Worldwide